



# Hero Me Gen7

## Parts Selection and Assembly Instructions



**WHEN IT COMES TO COOLING  
EVERYBODY DESERVES A HERO!**

**Exclusively for Hero Me Gen7 Patrons**

# Hero Me Gen7

## Parts Selection and Assembly Instructions

### Table of Contents:

Hero Me Gen7 Introduction and Background	Page 3
3D Printer Models Supported by Hero Me Gen7	Page 4
Hotends, Extruders, Fans, ABLs, Etc. Supported	Page 5
Hotends NOT supported by Hero Me	Page 6
Integrated Extruder/Hotends NOT Supported by Hero Me	Page 7
Hero Me Gen7 Platform Dictionary	Page 8
Hardware Required to Assemble Your Hero Me Gen7	Page 11
Part Cooling Fan Selection Criteria	Page 13
Hero Me Gen7 STL Parts Orientation	Page 14
Hero Me Gen7 Exploded Diagrams of Parts Placement	Page 22
How to Determine Which STL Files to Select	Page 27
Required and Optional STL Parts for Your Hero Me Gen7 Setup	Page 30
Hero Me Gen7 Zip File Organization	Page 31
Hero Me Gen7 Parts Selection	Page 33
Hero Me Gen7 Basic Assembly	Page 35
ABL Sensor and Nozzle offsets for Firmware or GCODE	Page 53
3D Printer Model Specific Notes	Page 55
Hero Me Gen7 Orientation and Assembly Videos	Page 56
Thanks and Credits	Page 56
Change Log – See separate document in the Zip	Page 56

The Hero Me Gen7 documentation undergoes frequent edits as new printers and components are added. While this version has been significantly improved, with new sections and all other sections with additional details, I am sure there is lots of room for improvement. If you find any discrepancies or have suggestions on how the documentation for the Hero Me can be further improved, please send them to me at: [mediaman3d@gmail.com](mailto:mediaman3d@gmail.com). Or via the #hero-me-gen7 or #hmg7-support channels in the Hero Me Discord server. Be sure to review the #gen7-faqs channel first before posting your question as it may already be answered

## Hero Me Gen7 Introduction and Background

Welcome and thank you for selecting the Hero Me Gen7 cooling system for your 3D printer. The Hero Me was originally designed by Marcelino A. Mosquea S. (Kelokera) from the Dominican Republic and posted to Thingiverse.com in September of 2018. release.

By end of 2018 Marcelino was no longer active on Thingiverse, and not responding to questions and requests from the community. Seeing great feedback and interest from the community, I created my first full remix of the Hero Me (Gen2) in January 2019. Later in 2019, I was able to connect with Marcelino and he gave me his approval to take over the Hero Me project. Now 5 years on I continue to update the Hero Me and add support for new printers, hotends, ABL sensors and other addons.

The key design concepts behind the Hero Me is to provide superior part cooling performance and to make a system that is modular, to support different brands and models of printers, hotends, direct drives, fans, ABLs, and other addons. This core modularity has allowed for the creation of over 650 different addons and remixes across the community in the years since.

Now seven generations later, the Hero Me Gen7 continues with these key design guidelines. The Hero Me Gen7 has maintained backward compatibility for most of the parts for Gen5 and Gen6. The flexibility of the Hero Me Gen7 also makes it future proof, as it also supports new tool changing systems, including the Wham Bam MUTANT, PrinterMods Xchange, and the BigTreeTech HermitCrab as well as the newly popular Orbiter and Sherpa direct drive extruders among many others. The Hero Me Gen7 is one of the top 2-3 aftermarket part cooling systems available on the Internet, now with over a half million downloads.

Hero Me Gen7 simplifies assembly and make future hotend maintenance and/or upgrades much easier by using threaded heat pressed inserts (no more M3 nuts to deal with). The HMG7 suite of parts will be compatible with future Hero Me releases and generations.

The instructions below will help you to select the parts needed for your printer as well as guide you through printing, assembly, and setup to be able to make great things with the Hero Me Gen7 and your 3D printer. This is the fourth generation of this document. While it has been significantly improved, I am sure there is lots of room for improvement. If you find any discrepancies or have suggestions on how this manual for the Hero Me can be further improved, please send them to me at: [mediaman3d@gmail.com](mailto:mediaman3d@gmail.com).

If you do not find your specific printer/model, hotend, direct drive, ABL, or other setup covered in this document, check out the Remixes tab of the Thingiverse and Printables projects or my Thingiverse and Printables.com collections of Hero Me compatible designs, as there are now over 700 remixes, adaptations, and compatible add-on parts for the Hero Me Gen7.

<https://www.printables.com/model/39322-hero-me-gen7-master-suite/remixes>

<https://www.printables.com/@MediaMan3D/collections/113081>

<https://www.thingiverse.com/mediaman/collections/hero-me-cooling-systems>

<https://www.thingiverse.com/thing:3182917/remixes>

## 3D Printer Models Supported by Hero Me Gen7

This is a continually growing list of 3D printers that are compatible with the Hero Me Gen7. Many more 3D printer brands and models are supported by the community in either the remix section or in my collection of Hero Me compatible designs found on [Thingiverse.com](https://thingiverse.com) or [Printables.com](https://printables.com).

Other manufacturer's clones of the Creality CR series, Ender series and Name brand 3D printers that are not listed below may be compatible but have not yet been tested.

### Over 104 3D Printer Models - 3<sup>rd</sup> Party X Axis Kits - X Carriage Plates are Supported!

<p>3DFused V1, V2, V3, CoreXY, Master X carriage                  Alfawise U20-U30                  Anet ET4, ET5, E10, A8                  Anycubic Vyper, Chyron, Mega S, Mega Zero, Kobra Go                  BigTreeTech HermitCrab                  BIQU B1                  BLV Ender 3 Linear Rail Upgrade                  BLV MGN Metal Cube                  CR-6SE                  CR-10, V2, V3                  CR-10 Mini                  CR-10S, S4, S5                  CR-10S Pro, Pro V2, Pro V3                  CR-20                  CR-MAX                  Elegoo Neptune 2, 2S, 3, X, 3 Pro, 3 Plus, 3 Max                  Ender 2 Pro                  Ender 3, 3 Pro, 3 Neo                  Ender 3X                  Ender 3 V2                  Ender 3 V2 Neo                  Ender 3 MAX, 3 Max Neo                  Ender 5, 5 Pro, 5 Plus                  Ender 6 CoreXY                  Eryone Thinker SE                  Exoslide                  Geeetech A10, A20, A30</p>	<p>HyperCube                  Kingroon KPS3                  Kywoo                  Labists ET4                  Lantro                  Linear Rails MGN9-H, MGN12-C, MGN12-H                  Longer LK1, LK5 Pro                  LulzBot TAZ 5/6/Pro/Sidekick/Mini                  MatterHackers Pulse SE                  Mercury One                  Micro Swiss DD kits (Ender 3, Ender 5, Exoslide, Linear Rails)                  OpenBuilds Mini V                  PrinterMods xChange &amp; MDD kit V1.2, V1.3                  RepRap i3 Clones, Prusa MK3S/+                  SainSmart Coreception 300                  Sovol SV01, SV02, SV05, SV06, SV06 Plus                  Sunlu S8                  Tevo Tarantula Pro, Tornado                  Tronxy X5SA Pro                  Two Trees Bluer, Sapphire Pro, Plus                  Wham Bam MUTANT                  Wham Bam Universal X carriages (v-wheel, linear rails)                  Voron 2.4, Switchwire-Afterburner                  Voxelab Aquila-Pro                  ZYLTech Gear V3                  Most clones of Creality CR &amp; Ender printers</p>
--	---

### This Release of the Hero Me Gen7.3.2 STLs support:

Over 104 3D Printer models (plus clones)  
 46 Hotends  
 34 Extruders (40 mount options)  
 17 ABLs

35 Part Cooling Duct options  
 12 Cable Management options  
 11 ADXL345 mounts  
 4 LED bar mounts

Gen7 now supports **OVER 35 BILLION** possible 3D printer setups! Never fear, the Gen7 is a breeze for part selection.



**46+ Hotend Brands and Models Supported:**

- Anycubic Vyper V5 Stock
- Creality Stock MK8 (2 screw mount)
- Creality CR-10S Pro (2 screw mount)
- Creality Spider (350c max)
- Creality Spider High Temp (500c max)
- Creality Spider 3 Pro
- Creality Spider 4 Pro (Speedy Ceramic)
- E3D-Online V6 & Volcano
- E3D-Online Revo Six (aka Prusa MK3)
- E3D-Online Revo Micro (aka Mini)
- E3D-Online Revo Voron
- E3D-Online Revo CR
- Haldis Red Lizard K1 V6 (Dragon)
- Haldis Red Lizard K1 Pro-HF-UHF
- Haldis Red Lizard V5, V5 Pro
- Generic MK8
- Generic J-Head V5, V6
- Micro Swiss All Metal CR-10, 10S Pro
- Neptune Stock
- Phaetus Dragon
- Phaetus Dragonfly BMO-BMS-HIC
- Phaetus Rapido (aka ST, HF)
- Phaetus Rapido Plus (aka UHF)
- Phaetus X Voron Dragon ST-HF-UHF
- Phaetus TaiChi
- Slice Engineering Copperhead
- Slice Mosquito, Magnum, Magnum+
- Slice Mosquito for Creality
- TriangleLab Dragon SF-HF
- TriangleLab Rapido HF-UHF
- TriangleLab TCHC TD6 (aka: CHC, CHC Pro, PT1000 Pro)
- TriangleLab TCHC TR6
- TriangleLab CHC Mini
- Clones of any hotends above

**17 Auto Bed Level (ABL) Sensors Supported:**

- Beacon3D
- BLTouch
- CR Touch
- Creality OEM
- Euclid Probe
- EZABL Pro
- EZABL Pro Mini
- EZABL Micro
- HallION
- PINDA
- PL-08N
- Touch Mi
- TA Sensor
- Omron Sensor
- 8mm, 12mm & 18mm sensors
- Clones of any ABL sensors above

**34+ Extruder Brand and Models Supported:**

- Advanced 3D Printing FXD
- Bondtech BMG (and mirror)
- Bondtech BMG-M (and mirror)
- BMG Mini (clone)
- Bondtech LGX
- Bondtech LGX Lite
- Creality Stock Single and Dual Gear
- E3D-Online Titan
- EZR Struder
- HextrudORT
- Kingroon Titan Clone
- Micro Swiss DD kits: Ender 3, 5, Linear Rail, Exoslide
- Micro Swiss Dual Gear
- Orbiter V1.5 & V2.0 (and mirrors)
- PrinterMods MDD Kit
- Phaetus APUS
- Sailfin A, B, Sherpa Variants
- Sherpa Mini
- Sherpa Micro
- Sovol SV01 stock
- Vz-HextrudORT
- TriangleLab TBG-Lite
- TriangleLab TBG-S
- Voron, Switchwire-Afterburner
- Clones of any extruders above (look-alikes may not fit)

**Heat Sink and Part Cooling Fans Supported:**

- 4010 radial fan (single and dual)
- 4020 radial fan (single and dual)
- 5015 radial fan (single and dual)
- 5020 radial fan (single and dual)
- 4010 & 4020 axial fans for heat sink cooling

There are also 11 mounts for various ADXL345 accelerometer PCBs and other options like endoscope cameras and analog dial gauges.

Live technical support and private Discord community are available from MediaMan3D for as little as \$5 here:

<https://www.patreon.com/MediaMan3D>

Download Hero Me Gen7 Release 3.2 here:

<https://www.printables.com/model/39322>

## Hotends NOT Supported by Hero Me



While the Hero Me Gen7 supports the new 'Neo' family of Creality 3D printers (Ender 3 Neo, Ender 3 V2 Neo, and the Ender 3 Max Neo), the stock hotend used in the 'Neo' family of printers is not supported.

This hotend, along with the other two shown above, are the few hotends that the Hero Me system cannot support. The maximum width for hotends that will fit in the Hero Me Gen7 Base is 26.8mm wide. The hotends shown range from 29mm-38mm wide. The Creality 'Neo' hotend is currently only found in the three Creality Ender 3 based 'Neo' models.

If you have a 3D printer that has one of these hotends and you want to upgrade your printer to take advantage of the Hero Me system, replace the hotend with one from the hotend list on the previous page.

## Integrated Extruder/Hotends NOT Supported by Hero Me

The following Integrated extruder/hotends are not compatible with the current Hero Me Gen7 design architecture.

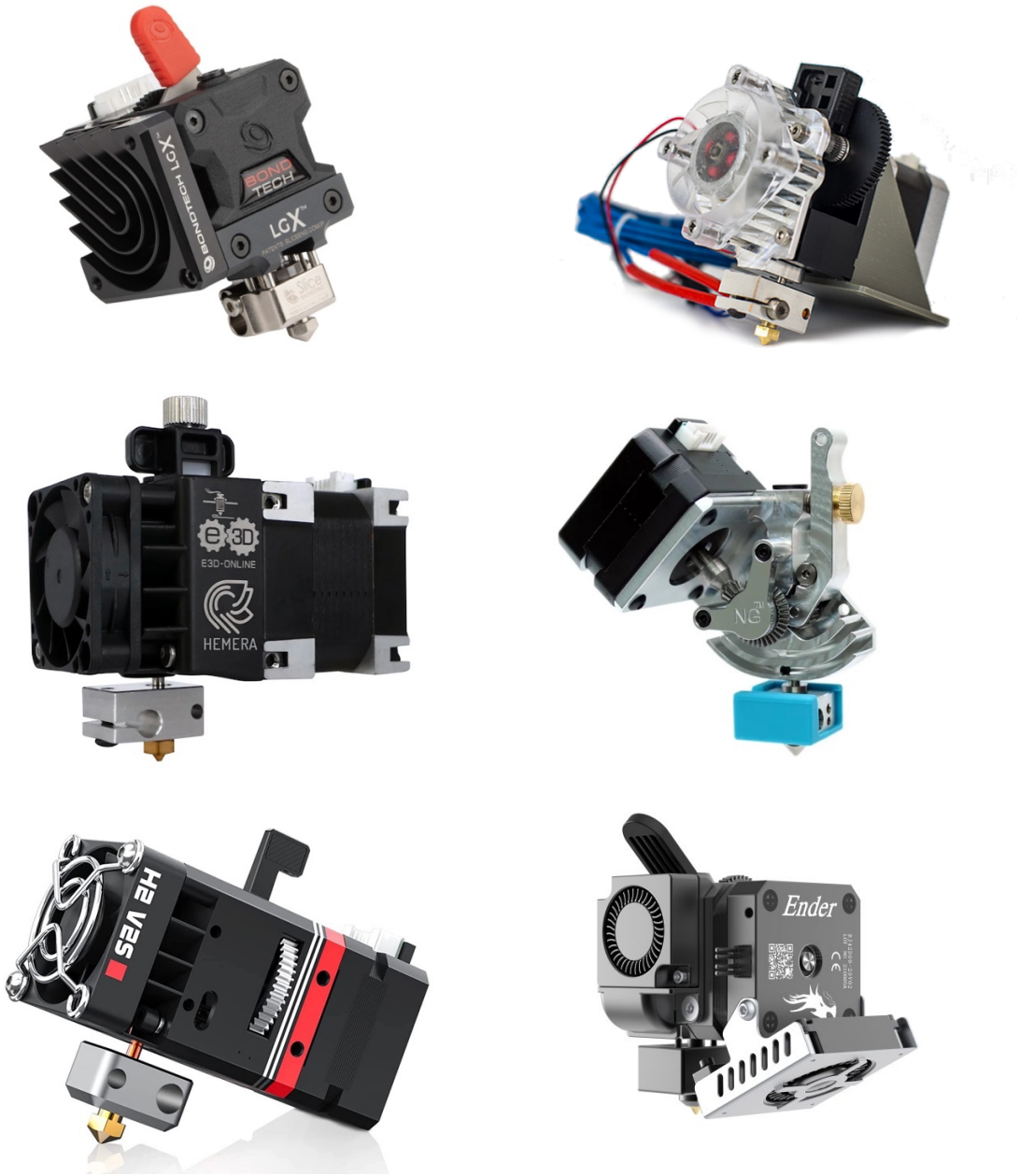

They are all too large, too wide, to fit into a Hero Me Base. The Hero Me was designed before these integrated extruder/hotend combos were developed. To make a Hero Me fit these assemblies it would no longer be a Hero Me as it would not be compatible with any of the hundreds of parts from both my Master Suite and the over 700 remixes and add-ons created by the community.

On a more positive note, I am working with another 3D designer/mechanical engineer to develop Hero Me based part cooling ducts with ABL & ADXL345 mounts for these integrated extruder/hotend combos. We hope to have them available in the near future.

## Hero Me Gen7 Platform Dictionary

**HMG7** – Hero Me Gen7

**Hero Me Base** – Core component of the Hero Me system with standardized mounts for hotend, fans, extruders, ABL sensor, ADXL345 and other components.

**Stack** – A term referring to the way a Hero Me holds the hotend and direct drive extruder. The Base is the platform, then a hotend mount ‘stacks’ on top of the Base. If an extruder is used, the direct drive mount is then stacked on top of the hotend mount. Each of the component STLs have ‘lego pins’ to ensure proper alignment of the components for the filament path to be straight. These are then secured together with two M3 screws.

**ADXL345** – PCB based accelerometer used with Klipper firmware to calibrate a 3D printer

**X carriage** or **Gantry Plate** – Metal plate that the hotend assembly mounts to on the X axis.

**Gantry Adapter** – the plate that marries the Hero Me Base to the X carriage of the 3D printer.

**Gantry Clip** – A small part that is used in some setups to help retain the Gantry Adapter to the X carriage because there are not enough mount points provided. Most all Gantry Clips are aligned on the right side of the X carriage from the back and line up to a mount point on the Gantry Adapter. The Gantry Clip for an Ender 5/Pro/Plus fits in the vertical slot of the X carriage from behind and lines up with two of the four mount points for the Hero Me Base and Gantry Adapter.

**Skirt** – Mounts to the bottom of the Hero Me Base. Provides a front mount point (e.g. ADXL345 accelerometers, etc.). Also prevents hotend heat sink fan airflow from dropping down and cooling the heat block.

**Part Cooling Duct** – fans attach to this part to cool the printed part below the nozzle

**DD** – Direct Drive extruder

**ABL** – Auto Bed Level sensor

**EZABL** – An ABL sensor from TH3D Studios

**E3D** – E3DOnline hotend manufacturer

**V6** or **E3DV6** – E3D Online hotend (collar mount)

**‘V6 Style’** – Creality hotend for the CR-10S Pro that looks like the E3D V6 but mounts with 2 screws horizontally

**Volcano** – E3D Online hotend (high flow, tall)

**Clone** – a copy of a name brand/model of 3D printer part

**Collar** or **Groove** – The type of mount used by E3D V6 hotends and clones

**Revo Six, Revo Micro, Revo Voron** – E3D Online hotend

**MK8** – standard hotend used by Creality (two screw horizontal mount)

**MS** – Micro Swiss All Metal hotend (MK8 clone)

**Mosquito** – Slice Engineering hotend (two screw top or collar mount)

**Copperhead** – Slice Engineering hotend (two screw top or collar mount)

**OEM** or **Stock** – used in reference to the stock part that came with the 3D printer

**BMO** – Phaetus Dragonfly BMO hotend (two screw horizontal mount)

**BMS** – Phaetus Dragonfly BMS hotend (collar/groove mount)

**HIC** – Phaetus Dragonfly HIC hotend (two screw mount, thicker heat sink)

**Dragon** – Phaetus Dragon hotend (Mosquito clone) (two screw top or collar mount)

**Spider, Spider 350, Spider 3 Pro** – Creality Spider high temperature hotends (collar or two screw horizontal mount)

**Rapido** – Phaetus Rapido hotend (Revo Six clone) collar mount

**HF** or **UHF** – Phaetus Dragon high temp, high flow hotends

**XY Offset** – a distance measured in mm. Often used to calibrate the position of an ABL sensor in relation to the nozzle of the hotend. Also used to set the Home position of the hotend via GCODE commands or instructions in the firmware of the printer.

**OEM-MK8-MS-MSDD-BMS** – Used in STL filenames. The STL is for use with hotends that match one of these types (or a clone of one).

**OEM** = Creality stock hotend as found on an Ender 3, Ender 5, or CR-10 class printers

**MS** = Micro Swiss All Metal hotend

**BMS** = Phaetus Dragonfly BMS hotend

**MSDD** = Micro Swiss Direct Drive kits

**MK8** = Generic MK8 (Creality OEM style) hotend

**E3DV6-Revo Six-Spider-BMO** - Used in STL filenames. The STL is for use with hotends that match one of these types (or a clone of one). This used for all collar/groove mount hotends.

**E3DV6** = E3D Online V6/Volcano

**Revo Six** = E3D Online Revo Six Family hotends (except Revo for Creality, Revo Voron)

**Spider** = Creality Spider series (350, 500, 3 Pro)

**BMO** = Phaetus Dragonfly BMO hotend

**Tall** – Used in STL part cooling duct filenames. STLs with this attribute are for use with very tall hotends (e.g. Rapido UHF, E3D-Online Volcano, etc.) These ducts are too tall for most hotends.

**Long** – Used in STL part cooling duct filenames. STLs with this attribute are for use with very specific printer setups when called for in the documentation (e.g. Micro Swiss DD kits, Neptune 3). These ducts should not be used for any other configurations, as the duct tips will be out of alignment with the nozzle.

**Brace** – Used in STL part cooling duct filenames. STLs with this attribute have a brace ring that connects to both fan mount points

**Lightweight** – Used in STL part cooling duct filenames. STLs with this attribute are lower weight

versions of the other equivalent ducts.

**Forward** – Used in STL part cooling duct filenames. STLs with this attribute have the fan moved forward more than other equivalent ducts. This enables a BLTouch or CRTouch to be mounted behind the left duct to be closer to the nozzle to improve the mesh created from leveling the bed.

**Dual** - Used in STL part cooling duct filenames. STLs with this attribute use two fans.

**Single** - Used in STL part cooling duct filenames. STLs with this attribute use one fan.

**Front** - Used in STL direct drive mount filenames. The stepper motor will face the front of the printer

**Rear** - Used in STL direct drive mount filenames. The stepper motor will face the back of the printer

**Mirrored** - Used in STL direct drive mount filenames. The extruder is a mirrored (left hand) version from the vendor.

**Riser** – Several sizes of spacer STL used to raise the position of a rear facing direct drive extruder to clear the top of tall X carriages (optional). Available in 4mm, 6mm, and 10mm. Multiples can be used if needed.

**Mount** - Used in STL filenames to denote that this part holds the component that is referenced in the filename. When used for ABL sensors the Mount STL holds the ABL sensor and connects directly to a Wing. This part controls the height of the ABL sensor in relation to the nozzle on the Z axis.

**Wing/Bracket** - Used primarily in STL ABL and filenames. The Wing or Bracket STL connects directly to the Base on the back left or back right side behind the part cooling duct mounts. This part controls the distance an ABL sensor is from the nozzle. Different widths (Compact, Close, Narrow, Standard, Medium, and Wide) are provided to ensure that space is made available based upon which Part Cooling duct(s) are used.

**Cable/Wire Tower** – Hotend/Extruder/Fan wire management – A pole with many mount points for zip ties to hold the power wires for the various components on the Hero Me.

# Hardware Required to Assemble Your Hero Me Gen7

The Hero Me Gen7 system uses M3 screws and M3 threaded inserts to secure all the components together and mount it to your printer's X carriage. You will need a soldering iron (preferably with an insert tip) to install the inserts into the Hero Me parts. The specifications are as follows:

M3 threaded inserts: 4.6mm outer diameter by 4mm length ← Preferred. Note that 3mm – 5mm lengths are acceptable.

The common M3 inserts with 5.6mm lengths are TOO LONG, do not use them as they will interfere with mounting the hotend and other components.

M3 threaded inserts Quantity: 35-50 inserts per Hero Me Gen7 assembly.

M3 screws Quantity: As there are over 1 billion possible combinations of Hero Me Gen7 components, I cannot know the total number of M3 screws or what sizes any given Hero Me Gen7 setup will require. I recommend that you purchase (if you don't already have a selection) an M3 screw assortment box that has M3 hex socket head or button head screws from 6mm to 30mm lengths.

Here is an example of the type of M3 threaded inserts to use:

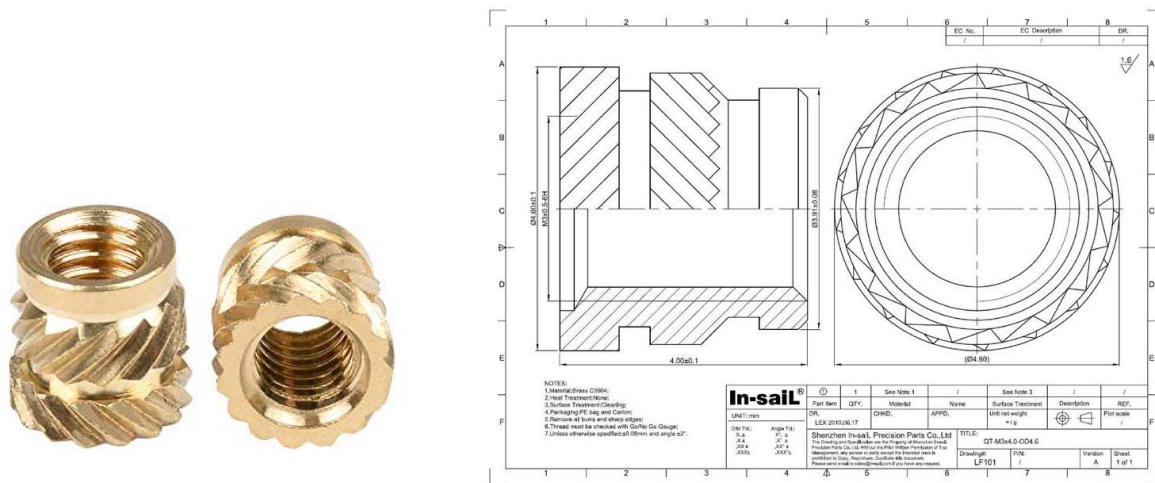

Note that they do not have to be the brand shown above.



Here is an example of the type of M3 screw assortment kits to use:



Here are links to sources for M3 screws and threaded inserts:

- KB3D. A bit expensive (sold by the piece) but the perfect size: [kb-3d.com/store/inserts-fasteners-adhesives/97-brass-heat-set-threaded-insert-for-plastic-m3x46x4mm.html](https://kb-3d.com/store/inserts-fasteners-adhesives/97-brass-heat-set-threaded-insert-for-plastic-m3x46x4mm.html)
- Fabreeko. A little longer than I like, but still works: [fabreeko.com/collections/v2-4/products/threaded-heat-inserts-m3x5x4-100pc-per-bag](https://fabreeko.com/collections/v2-4/products/threaded-heat-inserts-m3x5x4-100pc-per-bag)
- Amazon. Perfect size, 100pcs.: <https://www.amazon.com/dp/B08T7M2H4S>
- Amazon. Perfect size, fewer pieces (more than enough for a couple Hero Me setups) but also includes a proper tip for a soldering iron: [amzn.to/3nMnSsJ](https://amzn.to/3nMnSsJ)
- CNC Kitchen EU. Perfect size, 100pcs: <https://cnckitchen.store/Gewindeeinsatz-threaded-insert-M3-Short-100-Stk-pcs-p431146045>
- Prusa3D. EU. Perfect size, 100pcs: <https://www.prusa3d.com/product/threaded-inserts-m3-short-100-pcs>
- (Amazon Italy) 100pcs: <https://www.amazon.it/gp/product/B09ZHSGHXD/>
- Amazon US: 300PCS M3 Hex Socket Head Cap Screws Assortment Set Kit with Storage Box: <https://www.amazon.com/Stainless-Screws-300PCS-Assortment-Storage/dp/B094NHTRL5>
- Amazon US: 1350 Pcs M3 x 4/5/6/8/10/12/14/16/18/20/25/30 Stainless Steel 304 Hex Socket Head assortment: <https://www.amazon.com/iexcell-Stainless-Socket-Washers-Assortment/dp/B09XN629BF>



## Part Cooling Fan Selection Criteria

The Hero Me Master Suite is all about being able to custom match most any set of print head components AND provide the best part cooling.

All my Hero Me printers have dual 5015 fans & dual ducts. This is my recommendation for everyone upgraded their printers to get the most performance and flexibility out of the Hero Me Gen7 systems. But at a minimum, use a single 5015 fan.

The 4010-, 4020-, and 5020-part cooling ducts are all because of maker requests, as that is all they had. While 4020 and 5020 radial fans are acceptable, I DO NOT recommend using the stock 4010 fan from your 3D printer. 4010 fans do not produce enough static pressure to properly drive dual ducts, and a single duct 4010 will not properly cool the part as it only covers one side.

**A major reason for upgrading to the Hero Me is to get excellent part cooling.** Re-using the stock 4010 fan will not do this. I also do not recommend (or support) axial fans for part cooling (not enough CFM).

With dual 5015 fans (or any dual fan setup), never run them at 100% power. With a dual 5015 setup, you run the fans for normal printing at 40-45% power. This still gives you 3X the CFM (airflow over a stock 4010) AND it is all directed properly at the part below the nozzle.

The extra benefit is that they run whisper quiet. When you have extreme overhangs, or long bridges, set the fans power to 65-70%. 4020 and 5020 fans will work just fine, you just need to run them at slightly higher power settings (5020s generally do not produce as much static pressure as 5015s).

For great proof of what dual 5015's can do in a Hero Me setup, check this YouMakeTech YouTube video of an older Gen5 setup can do bridging 250mm with no supports and no sagging! While the whole 9-minute video is worth watching, the bridging starts at 8:05. <https://youtu.be/Cz-Ag00TL7M>

The best fans around are Sunon Maglev fans, but they are hard to find and 4X as expensive as the average fans. They can be \$18 each vs. two for \$9 on Amazon. When buying part cooling fans, be sure to look for fans that have the following in the description: "brushless, sealed, dual ball bearing". Do not buy fans that have 'hydraulic' in the description, as those need to be lubricated regularly.

Most of my printers are built with Winsinn fans. Here are two links to where the fans can be purchased:

Sunon: <https://spool3d.ca/sunon-5015-radial-centrifugal-fan/>

Winsinn: <https://www.amazon.com/WINSINN-Bearings-Brushless-Cooling-50mm15mm/dp/B08R9G2VDR>

## Hero Me Gen7 STL Parts Orientation

Hero Me Gen7 part selection in most cases is much simpler than with Gen6. First off, there is one universal Hero Me Base for 99.999% of possible setups (there are two other bases for special one-off uses cases, All-Access patrons also have the use of the Magnet Edition, but that is not covered here). All of the Hero Me Gen7 STLs are organized by part category and type. STL filenames contain the name of the specific components so it is easy to identify which ones you will need.

To help with orientation to Hero Me parts, I have created a 22-minute video post on the MediaMan3D Patreon page available to All-Access tier patrons and above.

<https://www.patreon.com/posts/hero-me-gen7-stl-74555664>

What follows are example photos of each type of Hero Me Gen7 part category with descriptions of their use and placement. This is followed by several exploded diagrams showing their positions in relation to all the other parts.

### Hero Me Gen7 Universal Base

This is the core of the Hero Me platform, everything mounts to the Base.

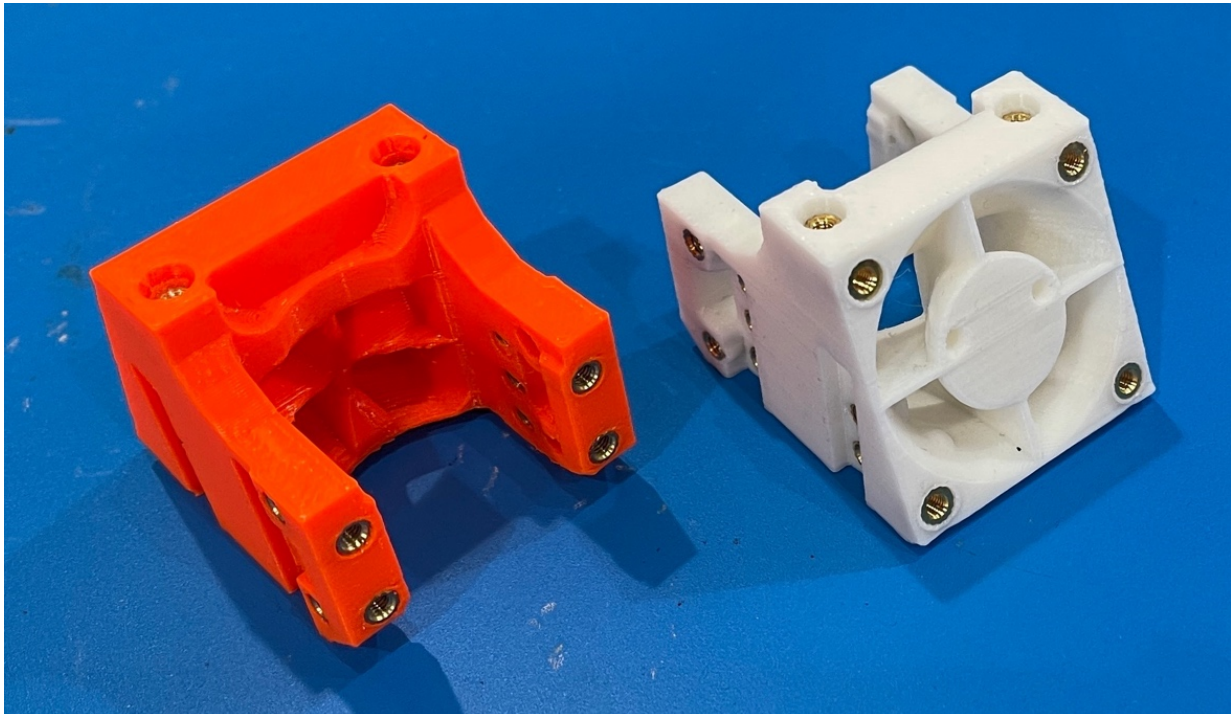

Front and back views of the Hero Me Gen7 Base.

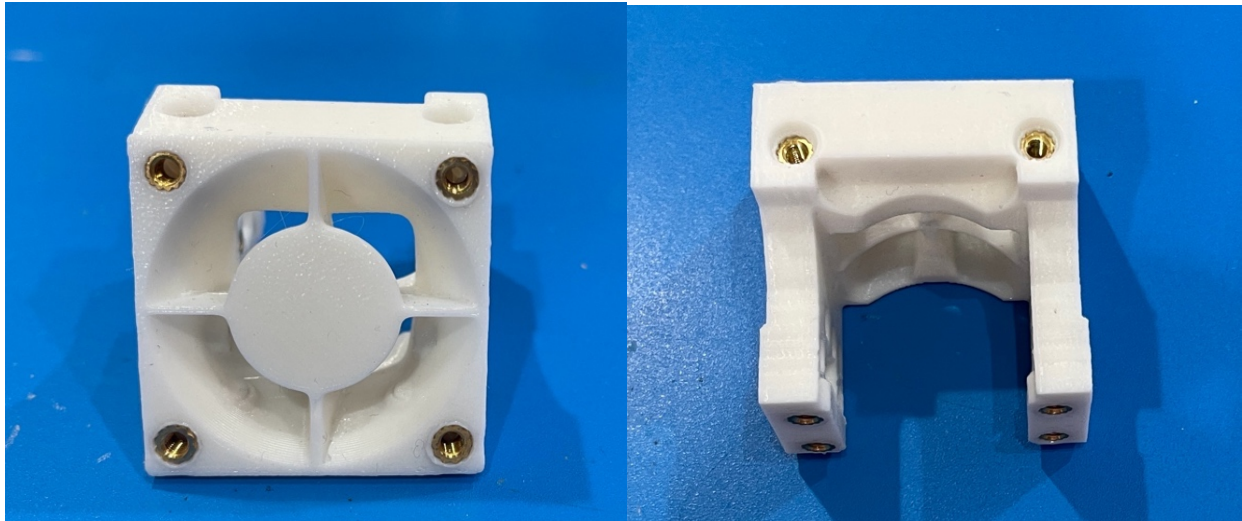

On the left is the Base's front face – these are the mount points for the heat sink fan.

On the right is the Base's top – The Hotend and its mount sits flush and square with the front edge. The 'Lego' style pins on the bottom of the hotend mount fit securely into the sockets on the top of the Base.

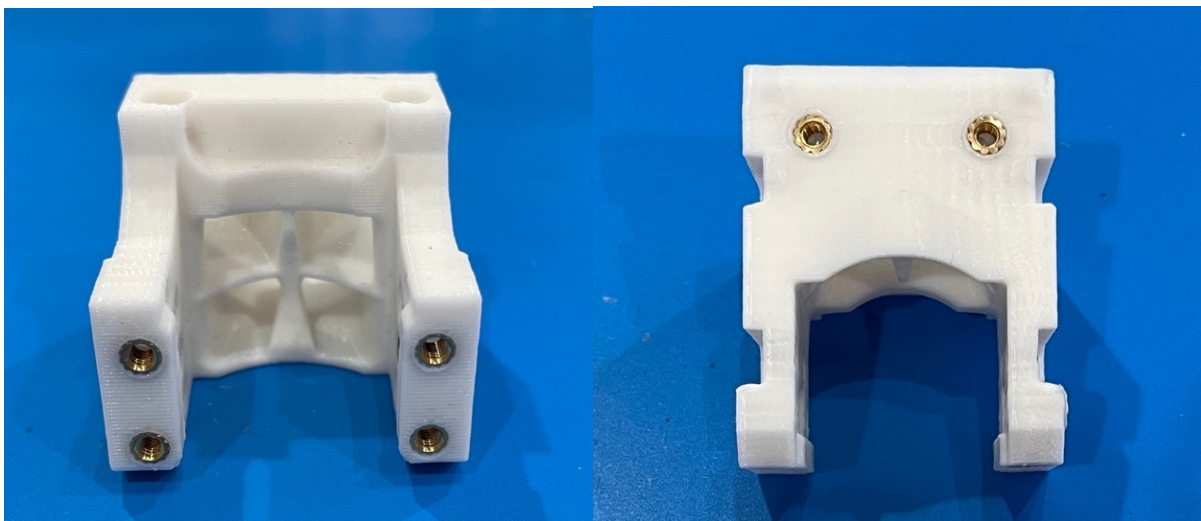

On the left is the Base's back – the Gantry Adapter holds the whole Base assembly from these four mount points.

On the right is the bottom of the Base – The Skirt mounts here to provide two forward facing mount points for options additions like ADXL345 accelerometers, Endoscope cameras, and other misc.





The two sides of the Base – There are two sets of mount points here. The five threaded inserts in the slots is where the part cooling ducts mount and provide vertical adjustments to set the duct tips 1.6mm off the bed when the hotend's nozzle is touching the bed.

### Gantry Adapters

The second set of mount points at the back left and right side are for ABL sensor mounts, Cable management towers or most any other options that can fit next to the ducts. These mount points are also stackable. You could have a Cable management tower and an ABL on the same side.

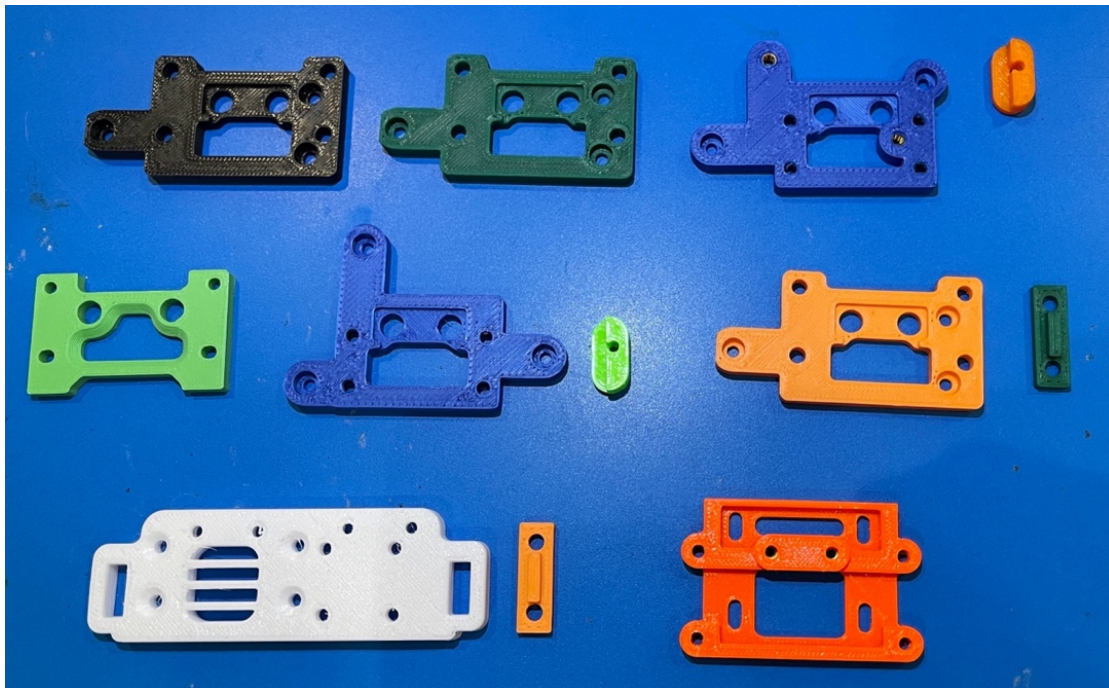

These are examples of the more than 100 different Gantry Adapters that mate the Hero Me platform to each 3D printer model. Some Gantry Adapters have one or two matching Clips that are used as a mount point to secure the Gantry Adapter to the X carriage. There are always (99%) at least 3 mount points to secure the Gantry Adapter to the X carriage.



## Hotend Mounts

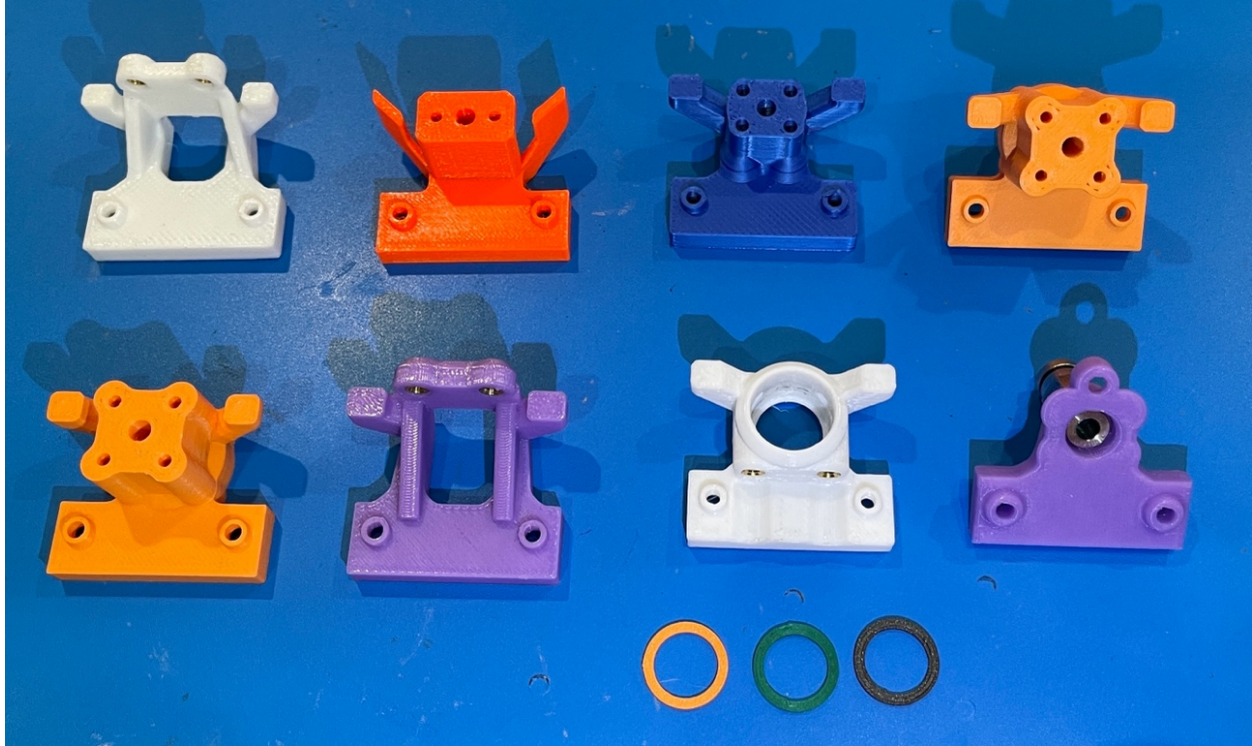

Hotend Mounts bottom view – These are just a few of mounts that hold the hotends (currently 46) securely on the top of the Base.



Hotend Mounts top view – The hotends are attached to to the base with 2-4 M3 screws and threaded inserts.

## Heat Sink Fan Guards

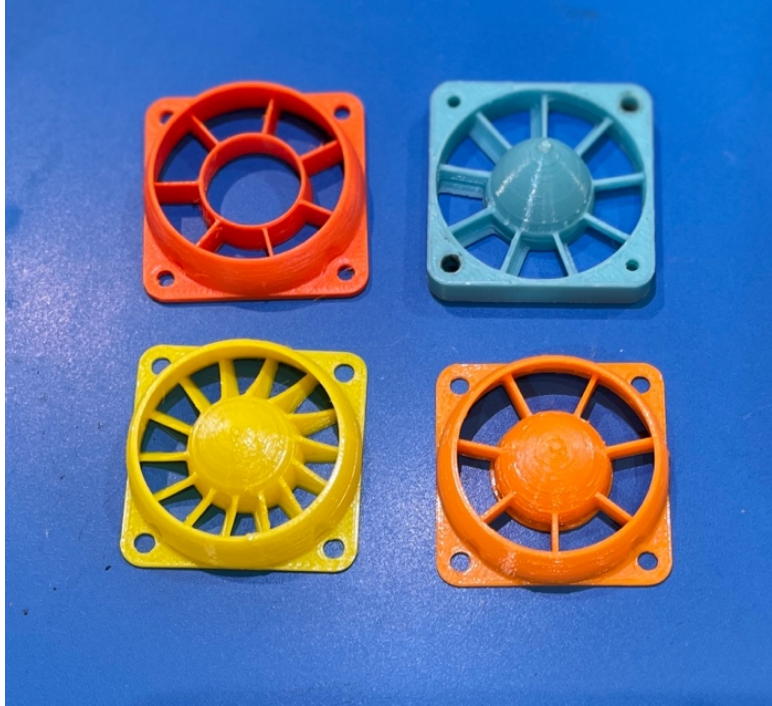

Heat sink fan shrouds – The Hero Me Gen7 has a few of these that can be used to protect the fan blades (and your fingers). You can also BYO most any fan shroud for a 40mm box fan that can be found in most any STL library on the Internet.

## Base Skirts



Base Skirts – These mount to the bottom front of the Base. They provide two threaded insert mount points to the front of the Hero Me Gen7 that are used for accessories such as ADXL345 accelerometer mounts, endoscope camera mounts, and anything else that would be if use in this position.



## Extruder Mounts

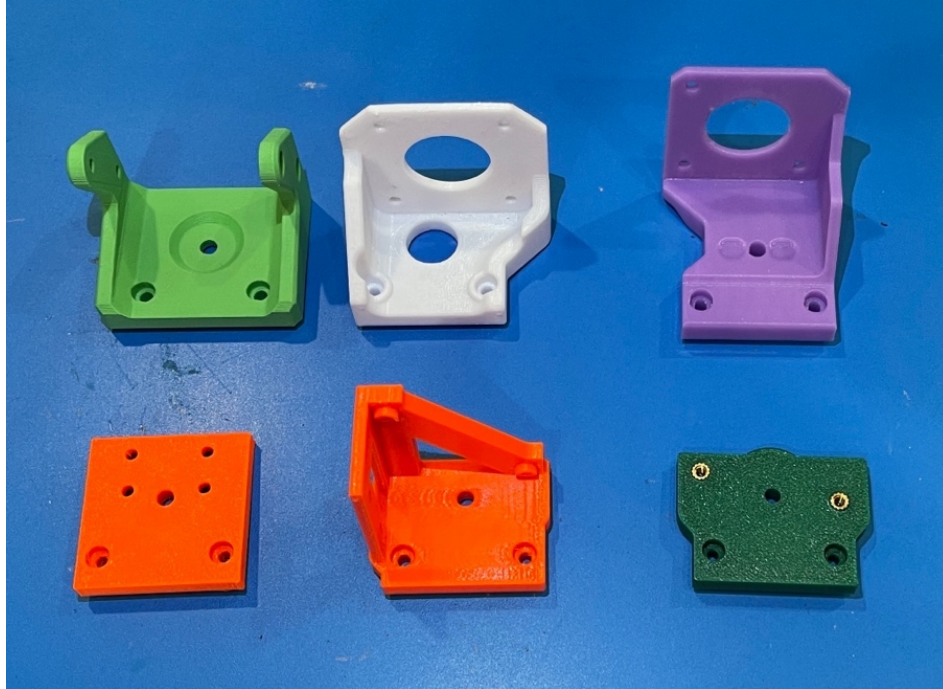

These are just six examples of extruder mounts (there are 34 plus variants). The extruder mounts to these, and the mount is stacked on top of the hotend mount and is kept in perfect alignment by the 'Lego style' pins and sockets. The 'stack' of the hotend and extruder mounts are held to the Hero Me Base by two M3 screws that hold the sandwich firmly together.

## Part Cooling Ducts

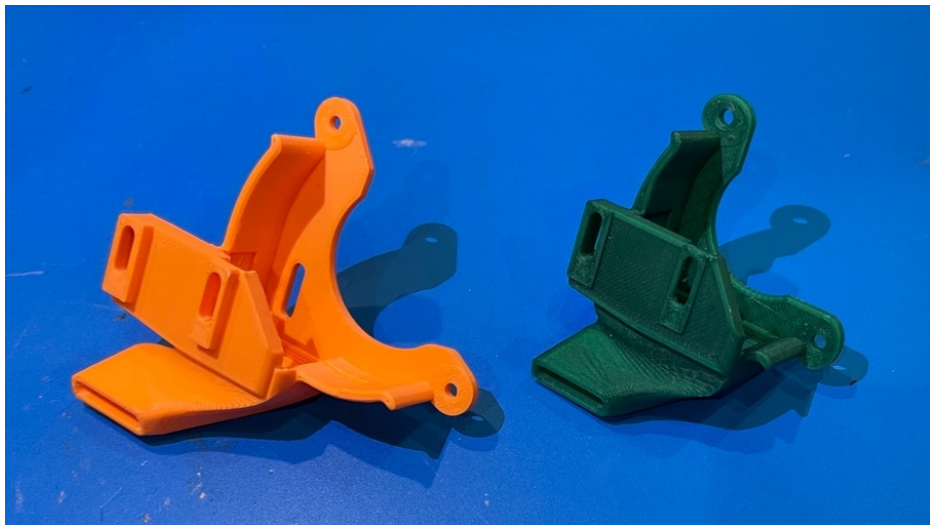

There are about 34 different part cooling ducts that support 4010, 4020, 5015, and 5020 radial blower fans. There are single fan, single ducts, and there are single fan dual ducts. There are three sets of these ducts: Standard, Long, and Tall. The difference has to do with which Hotend will be used in the Hero Me Base. Tall ducts are for the very tall hotends (Phaetus Rapido, E3D V6, etc.). Long Ducts are for use with the Micro Swiss Direct Drive kits (there are four) and the Neptune 3 and Anycubic Vyper. Basically, any 3D printer where the hotend is NOT mounted to the Hero Me Base, and the ducts need to reach further back to where the hotend is mounted to the X carriage of the 3D printer. The Standard duct are for everything else (97% of all use cases will use the Standard ducts).

## ABL Sensor (Wings and Mounts)



These are just a few examples of the dozens of ABL mounts that support the 17 ABL sensors that are supported (so far). For many of the ABLs (PINDA, EZABL, and other OEM cylinder style sensors with threads for vertical adjustments) there is just one mount needed. These mounts attach to the Hero Me Base in the back left-side or back right-side mount points (behind the part cooling duct mount points). There are versions of these mounts for left or right-side placement, as well as various lengths to get the mount out past the position of the part cooling duct(s) due to the different size fan(s) that can be used. These mounts allow the ABL to be positioned correctly in the Z axis in relation to the hotend nozzle.

For BL Touch, CR Touch and a couple other ABL sensors, there are two STL parts needed. The Wing STL is mounted to the left or right side of the Hero Me Base and provides a fixed position mount point. There are several versions of various lengths so that the ABL does not interfere with the part cooling ducts. This is due to the different sized fans used to cool the parts. There are versions for both the left and right side of the Base. Then there is the ABL mount STL itself, for the BL Touch and CR Touch there are several mounts with different orientations. These hold the ABL sensor and provides for vertical adjustment to handle whichever hotend is used, so that the sensor is the correct distance from the bed surface when the hotend nozzle is touching the bed.

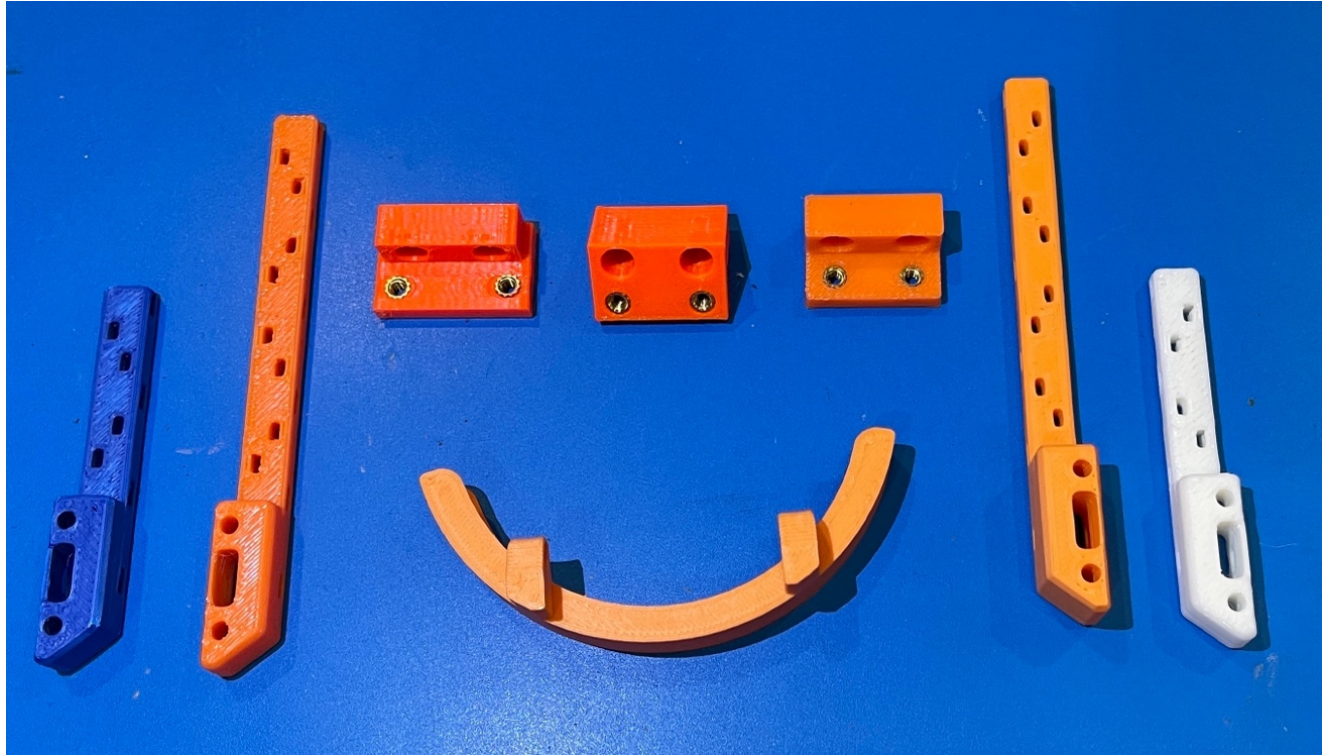

**Optional Mounts (Cable Management Tower, ADXL345 mounts, LED mounts)**

These are just a few examples of the optional mounts that can be used with the Hero Me Gen7. The 'stick' parts are the cable management towers. There are three different lengths to help with wire management, there are also 3 different mount widths to have the wire tower not interfere with some wide extruders. These can be used on either side of the Base and can be 'stacked' with the ABL sensor mounts on the same side if needed.

The small rectangular parts are examples of the 10 different ADXL345 mounts that attach to the Skirt in the front of the Base below the heat sink fan. Not shown are the endoscope camera mounts that are attached in the same location.

The curved STL is an example of an LED mount to shine on the hotend. These mount between two part cooling fans out front of the Hero Me Base. There are both curved and straight mounts that support 50mm and 100mm LED strips.

Summary – All the parts shown in the past few pages represent all the part types of the Hero Me Gen7 platform. The standardization of the mount points on the Hero Me Base has allowed the creation of a very large catalog of remixes and add-ons to the Hero Me platform by the community. There are now over 700 STLs made by the community that can be used with the Hero Me platform.

## Hero Me Gen7 Exploded Diagrams of Parts Placement

Now that you are familiar with the components that comprise the Hero Me Gen7 platform, Here are several 'exploded' diagrams with the Hero Me Gen7 components identified. Your specific setup may look different, but the component names and positions are all standardized.

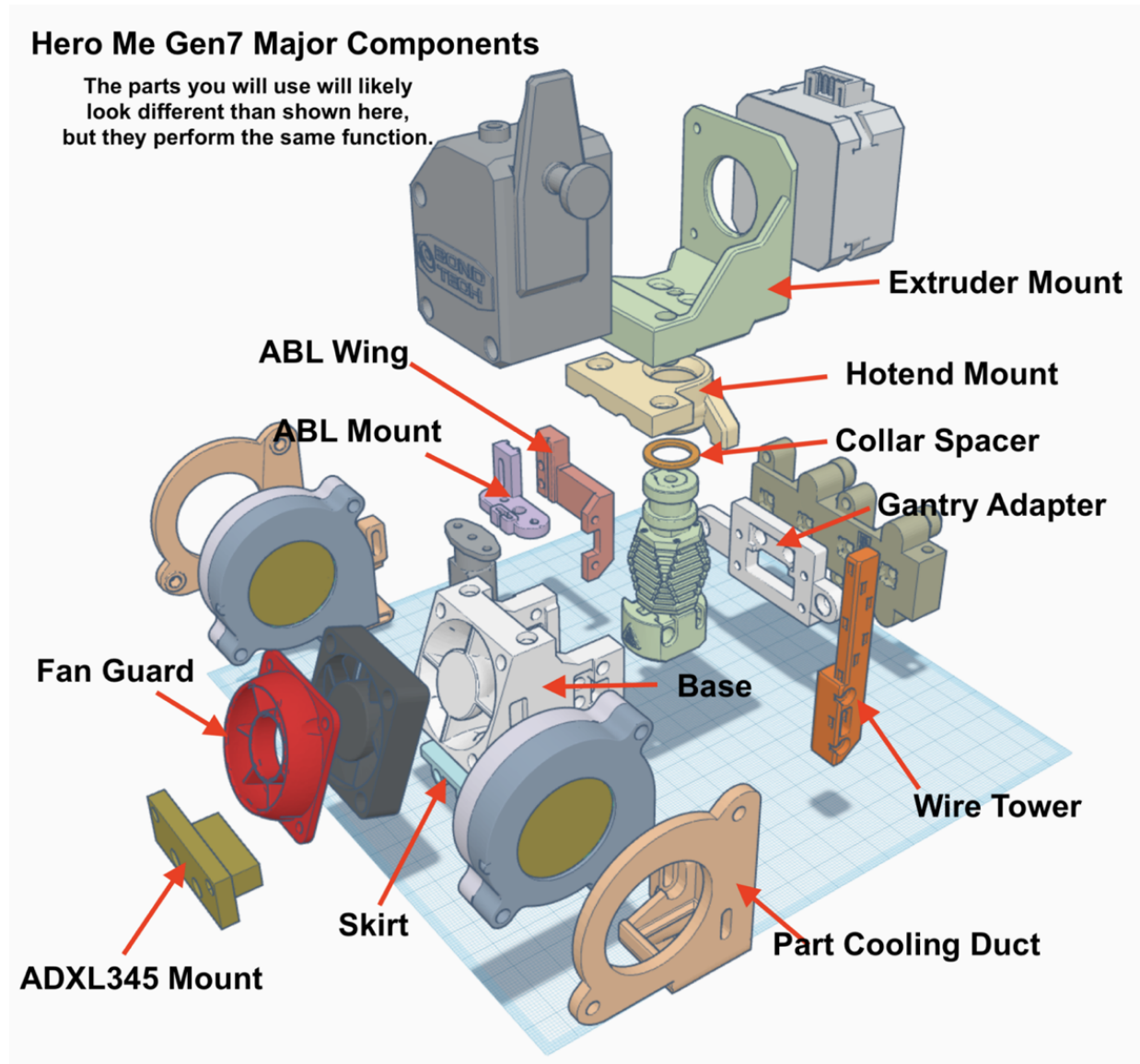

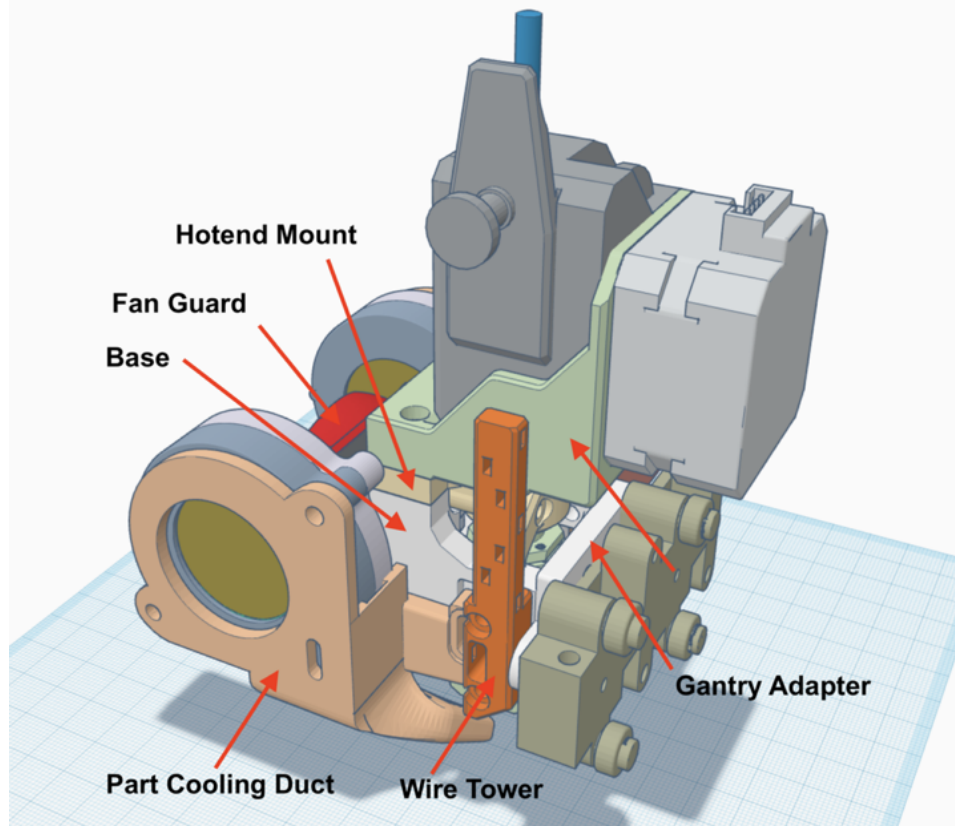
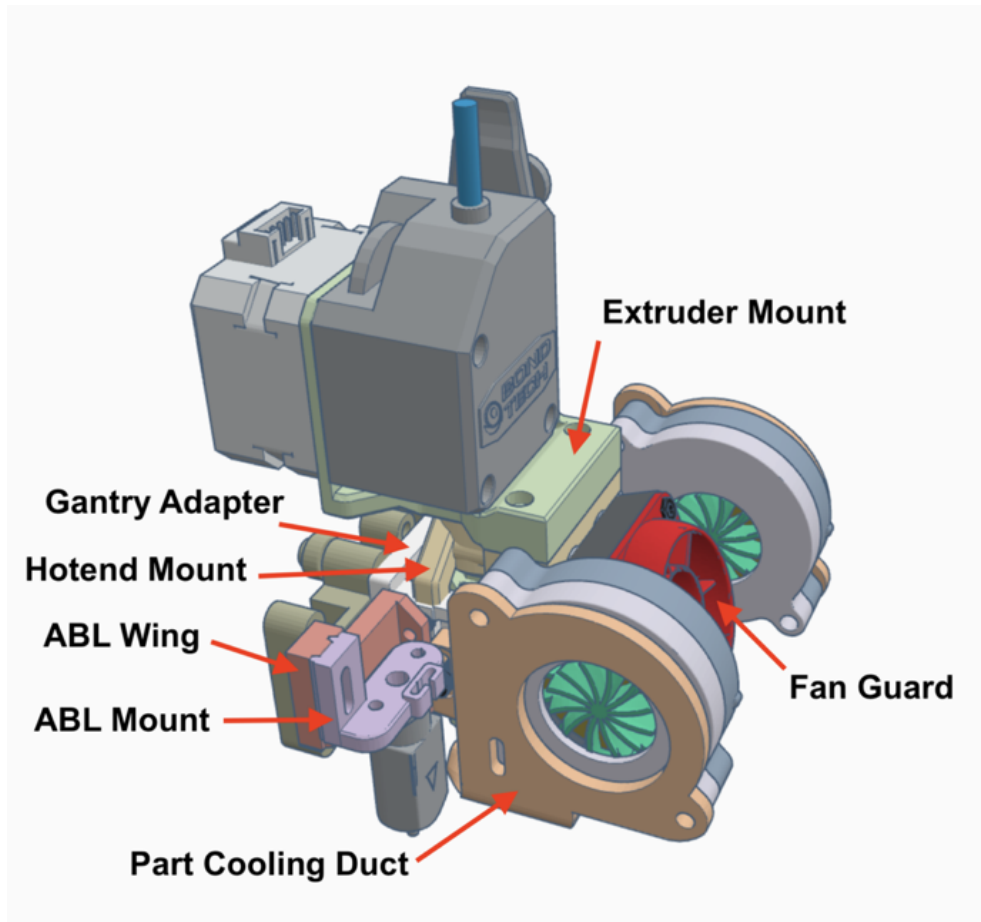



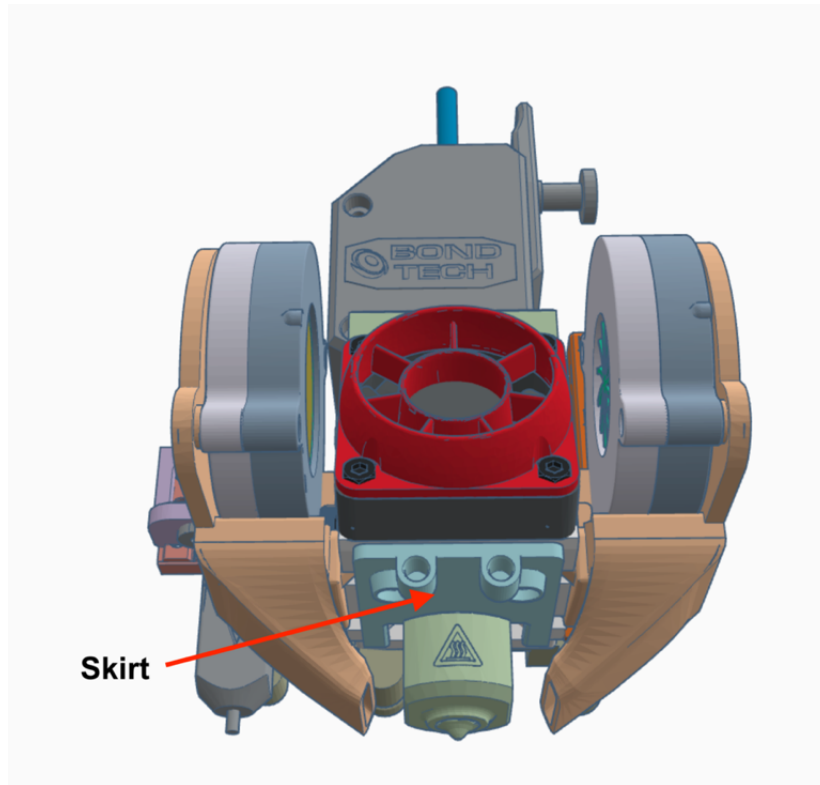

The following are several photos of two different Hero Me Gen7 setups with different hotend assembly hardware to show how it all comes together.



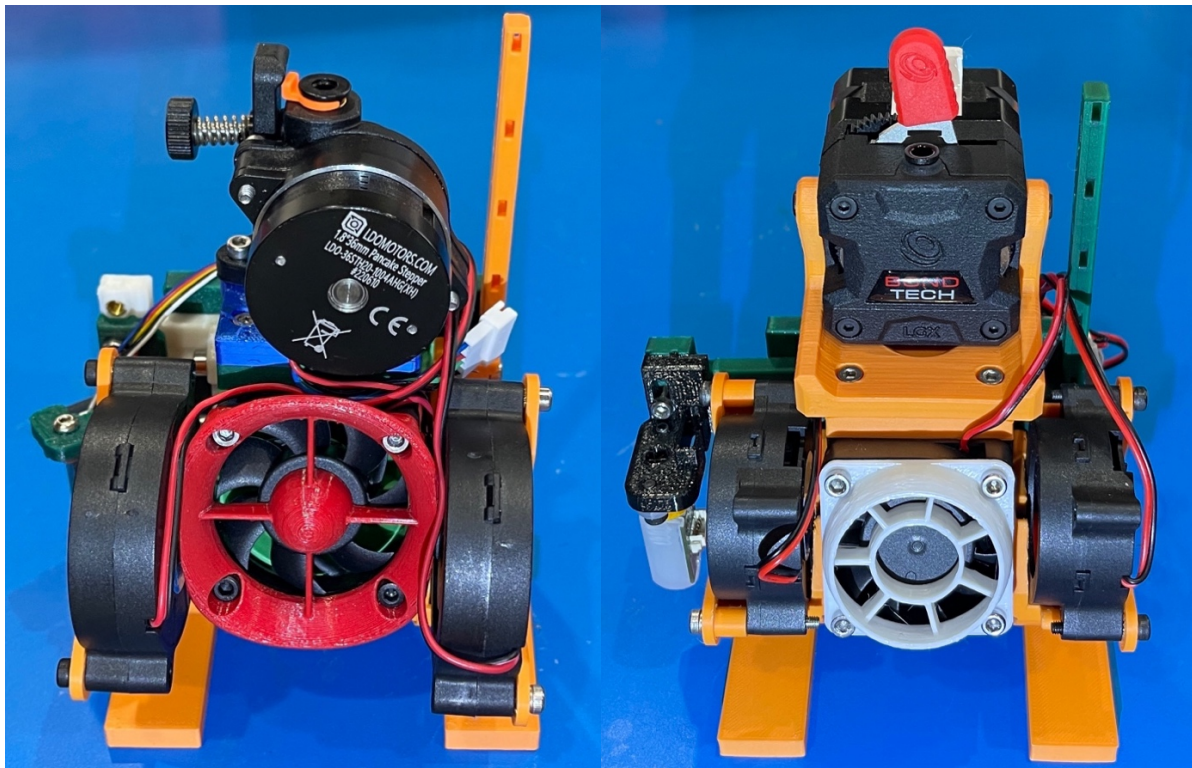
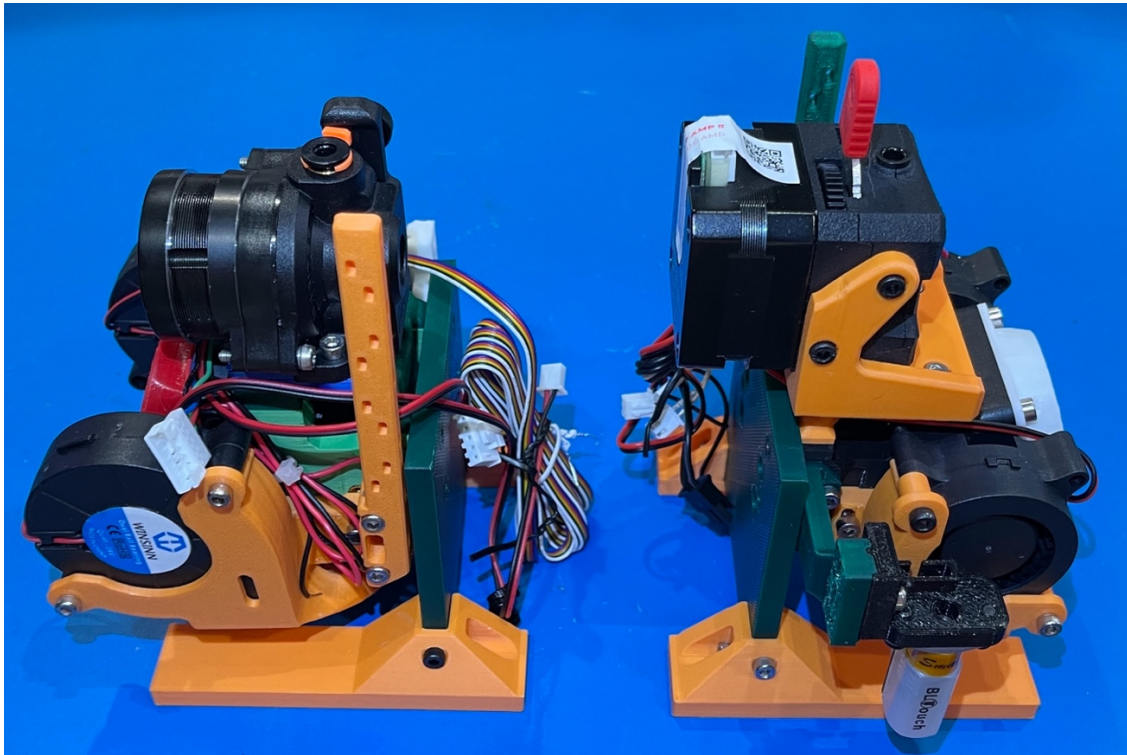



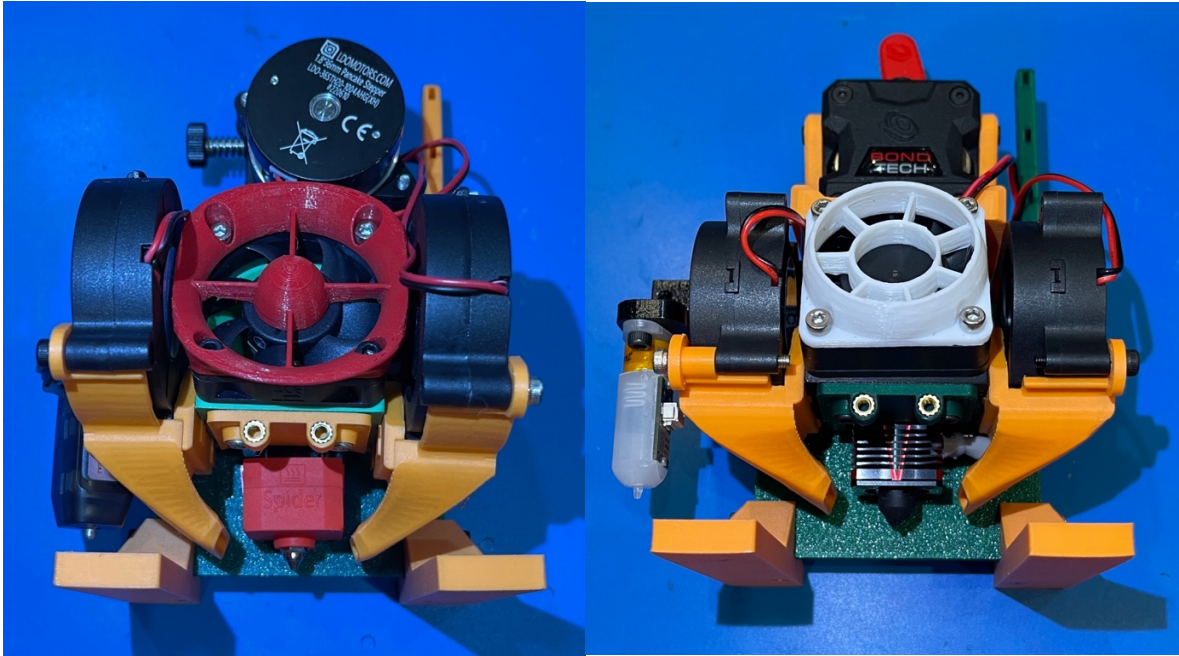

There are literally billions of possible combinations possible given all the different 3d printers, hotends, extruders, fans, ABLs, ADXL345s that the Hero Me Gen7 platform supports.

## How to Determine Which STL Files to Select

### Hero Me Gen7 STL Parts Section Questionnaire

If you have not already, download the latest release ZIP of the Hero Me Gen7 STL library from this Patreon post (It will always be the most current, as well as nicely organized in folders/sub folders by category and type of STL): <https://www.patreon.com/posts/hero-me-gen7-1-0-74115568>

If you are having trouble selecting the STL files needed for your Hero Me Gen7 upgrade, here are a set of questions about your 3D printer setup that you need to answer. Your answers will guide you to select the STL files you need for you unique 3D printer configuration.

### Questions About Your 3D Printer Setup (to help you know what to select)

1. What 3D Printer brand and model? (E.G. Ender 3 V2,, Ender 5, CR-10S Pro V3, Neptune 2, Voxelab Aquila, etc. etc.).

3D Printer Model: \_\_\_\_\_

2. Is your 3D printer's X carriage non-stock? (Yes, No)

If No, skip the next question. If the answer is Yes, the answer to the next question overrides the first question above, as this is used to identify the Gantry Adapter needed since the stock one is not being used.

3. Are you using a 3rd party X carriage? (Yes, No)
4. If Yes, what brand/model of x carriage are you using? E.G. PrinterMods MDD, , BLV, Micro Swiss DD kit (4 versions), 3DFused (5 versions), Wham Bam Systems Universal X carriage (there are two versions), or some other x carriage?

3D Party X Carriage Model: \_\_\_\_\_

The answers from the above questions are used to select the Gantry Adapter. The Gantry Adapter along with the Hero Me Base (Universal) are your starting point. Next...

5. What brand/model of hotend are you using? (E.G. Creality stock, Phaetus Dragonfly, Slice Mosquito, Micro Swiss, E3D V6, etc. etc.). With this you can find the Hotend mount that matches yours.

Hotend Brand: \_\_\_\_\_ Model: \_\_\_\_\_

6. Will you be using a Bowden extruder or a Direct Drive extruder? (Bowden, Direct Drive)

If you selected Bowden: Skip the next two questions as you now have the info for gantry adapter, base, and hotend mount.

If you selected Direct Drive:

7. What direct drive brand and model will be used? (E.G. Bondtech BMG, LGX, LGX Lite, Orbiter V1.5 or V2.0, Sherpa Mini, Titan, Creality Single or Dual Gear, etc.) This is needed along with the next question to select the correct Hero Me DD mount file.

Direct Drive Brand: \_\_\_\_\_ Model: \_\_\_\_\_

Some printers have tall X carriages that prevent having the stepper in the back (Rear/Reverse). Some printers with low enough X carriages may have other issues (tight X axis to Z axis assembly where a stepper would hit the aluminum extrusion before allowing the nozzle to get to X0). These issues require the stepper to face the front (Front/Forward).

8. Do you want the stepper motor to be in the front or rear of the extruder on the print head assembly? (Front/Forward, Rear/Reverse)

Note: Some extruders have a mirrored version (right hand, left hand). So, take note of this as the STLs have 'mirror' in the filename for left hand versions.

With the DD Brand/model, stepper orientation, and mirror info, you now have what you need to select the Direct Drive Mount.

Next, the type and number of part cooling fans (This helps identify which part cooling ducts to use):

9. How many part cooling fans? (1 or 2)
10. What size Fan(s)? (4010, 4020, 5015, 5020)

With this info you can find and select the part cooling duct(s) to match your fans(s).

11. Are you using an ABL sensor for bed leveling? (Yes, No).

If No, skip the next question.

12. What type of ABL sensor will be used? (E.G. BLTouch, CRTouch, EZABL, Pinda, TA sensor, etc.)

ABL Sensor: \_\_\_\_\_

This info identifies the ABL mounting part(s) needed. The selection of ABL mount parts is affected by which part cooling ducts are used, as the sensor needs to be positioned not to interfere with the part cooling duct. The variations of the ABL mounts affect how far from the nozzle they are mounted. BLTouch and CRTouch ABLs require two STLs (wing and mount). The wider the fans, the wider the ABL wing needed. There are versions of these to mount the ABL on either the left or right side of the hotend.

13. Will you be using an ADXL345 accelerometer for use with Klipper? (Yes, No)

If No, skip the next question.

14. If Yes, what is the length in mm (center to center) of the mount holes on the ADXL345 PCB. With this you can select the right ADXL mount.

ADXL345 PCB mounting holes measurement: \_\_\_\_\_

The rest of the questions below are all optional:

15. Do you want/need a heat sink fan guard? (Yes, No)

If Yes, there are several to pick from in the Options folder. Almost any 40mm fan guard can be used from other sources (Printables.com, Thingiverse.com, Thangs.com, Cults3D.com, etc.).

16. Do you want to use a tower to help with cable management? (Yes, No)



If Yes, there are a number of choices (sizes, placement) in the Cable Management folder.

17. Do you want to mount LEDs to shine on the hotend? (Yes, No)

If Yes, there are a couple of choices in the Options folder.

With the answers to all these questions, you can navigate the Hero Me Gen7 ZIP file (organized into component folders, then brand/type folders, and within those the filenames are very descriptive) to select the STL files that match the answers to the questions above.

Additional support notes, a detailed FAQ and other info are on the Discord server for All-Access patrons (and above). If you have not already, link your Discord ID to your Patreon profile so that the Patreon bot can assign your role in the Hero Me Discord server.

If after using your answers to the questions above and the instructions that follow, you still have trouble selecting the parts you need, support is available to All-Access patrons (and higher tiers) on the Hero Me Discord server. If you are Documentation patron, it is just a \$2 upgrade to get access to full support: including orientation and assembly videos, detailed FAQ guide, access to the private Hero Me Discord server and direct support from the developers.

All Hero Me support is done via the Discord server. To get the fastest most accurate support for your specific setup, post a message in the #hmg7-support channel with your answers to the numbered questions above so that I (or another Hero Me community member) can promptly and accurately help you.

## Required and Optional STL Parts for a Hero Me Gen7 Setup

You will need one or two each of the following STL components.

### Bowden Configuration

- 1 Hero Me Base
- 1 Gantry Adapter and possible Clip (that matches the model of 3D printer or 3<sup>rd</sup> party X carriage)
- 1 Hotend mount (that matches the hotend and mount type)
- 1- or 2-Part Cooling ducts (that match the size of part cooling fan(s))
- 1 Skirt (that matches the hotend being used)
- 1 Cable Tower

This is the basic setup for Bowden use.

### Direct Drive Configuration

To add an extruder to the Hero Me in a Direct Drive configuration, you will also need the following STLs:

- 1 Extruder direct drive mount
- 1 or 2 Risers (or none in most cases)

### Optional Additional Components

The following STL components are OPTIONAL to the Hero Me, but may be required depending on your specific setup:

- 1 ABL mount (some ABLs need two STLs, a mount and a wing.)
- 1 Heat sink guard/shroud for the heat sink fan
- 1 ADXL345 mount
- 1 Cable management tower
- 1 LED mount

## Hero Me Gen7 ZIP File Organization

**IMPORTANT:** All the STL filenames are detailed with what brand/model, type, size, orientation etc. for the type of component they are for. Look for your components' names or function in the STL filenames. Note that many hotend and extruder clones with the same mount type may not have their brand name mentioned, those will use the STL for the component they are a clone of.

The ZIP of Hero Me Gen7 STLs is organized as follows (in alpha order):

- ABL Mounts
  - Beacon3D ABL Sensor
  - All the individual Gen7 ABL Brackets and Mounts
- ADXL345 Mounts
- Base
- Cable Management
- Extruder Direct Drive Mounts
  - Bondtech
  - Creality
  - DyzeXtruder
  - E3D-Online
  - EZR Struder
  - Orbiter
  - Phaetus
  - Sailfin
  - Sherpa
  - Sovol SV01
  - TriangleLab
  - Zesty Nimble
  - All other extruder mounts
- Gantry Adapters
  - 3DDFused
  - Alfawise
  - Anet
  - Anycubic
  - BIQU
  - BLV
  - Creality
  - Elegoo Neptune
  - Hotend-Gantry Standoffs (for some Bowden setups)
  - Linear Rails
    - Ender 3 Style
    - Ender 5 Style
    - HyperCube – BLV Style Linear Rail
    - Mercury One Style
    - Misc Linear Rail Mounts
    - Voron CoreXY Style
  - Longer
  - Micro Swiss
  - PrinterMods
  - RepRap – Prusa – Clones
  - Sovol
  - Sunlu
  - Tevo
  - Two Trees
  - Wham Bam

- ZyLTech
- All the other Gantry Adapters
- Hotend Mounts
  - Hotends
  - Skirts
  - Misc. Hotend spacers and caps
- Options
  - All the optional components, fan guards, LED mounts, endoscope mounts, cable clips and much more.
- Part Cooling Ducts
  - Long Ducts - Vyper-Kobra-Neptune 3-Micro Swiss Direct Drive
    - 4010 fans
    - 4020 fans
    - 5015 fans
    - 5020 fans
  - Standard Ducts
    - 4010 fans
    - 4020 fans
    - 5015 fans
    - 5020 fans
  - Tall Ducts - E3D Volcano-Phaetus Rapido-UHF
    - 4010 fans
    - 4020 fans
    - 5015 fans
    - 5020 fans

## Hero Me Gen7 Parts Selection

Using your answers from the Parts Cross Reference Prep section above, select the STLs you need to print for your printhead configuration from the unpacked Gen7 ZIP:

1. Get the Hero Me Gen7.2 Universal Base STL and the Universal Skirt STL. There are three Base STLs, but 99.999% of you will use the Universal Base, the filenames of the other two identify which scenario would require their selection instead. The Skirt STL is mounted to the bottom of the Base.
2. Select the Gantry Adapter STL for your specific 3D printer model. Note that if you are using a 3<sup>rd</sup> party X carriage, tool changer, etc., then select the Gantry Adapter for that 3<sup>rd</sup> party upgrade. This is because the Hero Me system only cares about the X carriage it will mount to, not the printer model (if the X carriage has been replaced).
3. Select the Hotend Mount STL that matches your hotend. If your hotend is not listing in the filenames and it has a collar mount option like the E3D V6, then you will use the collar mount with your hotend (HMG7 E3DV6-Revo Six-BMO Collar Mount V2.stl) along with one of the collar spacer STLs (start with the 1mm spacer).

The hotend is attached to the mount, and the mount is stacked on top of the Hero Me Base.

4. Optional: Select an Extruder direct drive mount STL if you are going setup for Direct Drive use. There are both 'Front' and 'Rear' versions of most extruder mounts (and some have 'mirror options'). This refers to the location of the stepper motor. Select the appropriate mount for how you want the extruder/stepper positioned.

The extruder and stepper are attached to this mount, and the Extruder mount is stacked on top of the Hotend mount. If you are using a rear facing extruder setup, and the stepper motor does not clear the height of the X carriage, you have two choices: 1. Use the front facing extruder mount instead. Or, 2. Print and add one or more Riser STLs as needed to clear the top of the X carriage. Risers are available in 4mm, 6mm, and 10mm heights and are placed between the Hotend mount and the Extruder mount.

5. Select the part cooling duct(s) STL(s) for the fan(s) you will be using.
  - a. The following 3D printers must part cooling duct STL(s) from the 'Long Ducts' folder:  
All Micro Swiss DD kits  
Anycubic Vyper or Kobra  
Neptune 3
  - b. If you are using a very tall hotend (e.g. Phaetus Rapido, E3D Volcano, etc.) then you will be selecting your part cooling duct STL(s) from the 'Tall Ducts' folder.
  - c. For all other setups, Select the ducts from the 'Standard' ducts folder.

My recommendation for part cooling is to use dual 5015 fans to get the best performance from your Hero Me Gen7 setup. I use the 'HMG7.3 Standard Single 5015' Left and Right ducts on all my 3D printers.

6. Optional: Select the ABL wing & Mount/Bracket STLs for the ABL sensor you will use. ABLs can now be mounted on the left or right side of the Base.
7. Optional: Select one of the cable management tower STLs you want to use. There are both right and left side versions. The 5mm and 10mm widths are for direct drives that are too

wide, otherwise preventing the cable tower to mount to the side of the base.

8. Optional – Select (or provide your own) heat sink fan guard from the Options folder. These are to protect the heat sink fan blades (and your fingers).
9. Optional – ADXL345, LED, and other mounts are provided in the Options folder as needed for your specific setup requirements. These mount to the Skirt STL in the bottom front of the Base.

There are also over 650 add-ons and remixes available on [Thingiverse.com](https://www.thingiverse.com) and [Printables.com](https://www.printables.com) that may meet your needs if you have a component that is not part of the Hero Me Gen7 inventory.

## Hero Me Gen7 Basic Assembly

### Print the parts you have selected.

The parts are pre-oriented for best print results. Most parts do not require supports, those that do, only need minimal support (you need less than you think) and most are build plate only.

Recommended printer settings for Hero Me STLs:

- Layer height: between .2mm to .28mm (lower is fine, but not required)
- Perimeters: 3 walls
- Infill: At least 35%.

If you use a silicone sock on your printer's hotend, you can use PLA+ for the Part Cooling ducts, Hero Me base, and Skirt STLs.

I highly recommend using a silicone sock for you hotend in all cases. I have printed for four years with the Hero Me made from 100% PLA+ with no warping or melting because I have always used a silicone sock.

If you do not have a silicone sock and are only printing PLA, PLA+, and PETG, then you must print the STLs in PETG (or higher temp filaments).

If your 3D printer is enclosed in a chamber, or you plan to print ASA, ABS, Nylon, or other high temp filaments, then you must print the Hero Me parts in at least ASA or ABS.

**Only use support settings from the build plate only. I highly recommend for the few STLs that require support, to manually place the supports. Be sparse, you will need less than you think.**

The Part Cooling ducts only need support for the overhangs and just in front of some ducts. Do not place supports inside the tubes of the part cooling ducts.

### Clean and trim the parts as needed, then install the threaded inserts.

Test fit all the parts before assembly (and before installing inserts) to be sure that you have a good fit and proper contact. Test fit again after installing the inserts.

Install the M3 threaded inserts into all the parts that require them. The Hero Me Base will have at 26 holes that need M3 threaded inserts. Extruder mounts will use two to four M3 threaded inserts.

Other parts that use the inserts are the Hotend Mounts, some Part Cooling ducts, some ABL wings or brackets, and some Gantry Adapters and Gantry Clips.

For the Hero Me Base, install M3 threaded inserts in all the round holes. Do the same for the hotend and extruder mounts. DO NOT put an insert in the filament path of any part.

There are two new threaded insert holes on the top of the Hero Me Gen7 Base. These are deep, with the M3 insert hole inset within the wider hole; you want the inserts to be flush with the lower ledge. The top area needs to be clear so that the round tabs of the hotend mounts to mate and allow the Base and Mount to be flush with each other.

There are several great YouTube videos that show the correct way to install the threaded inserts into your parts. The following images show the proper placement of threaded inserts in the Base.

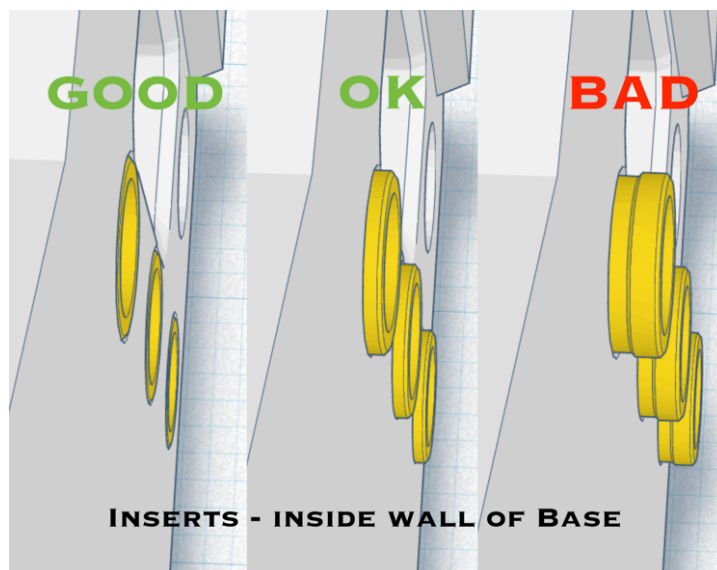
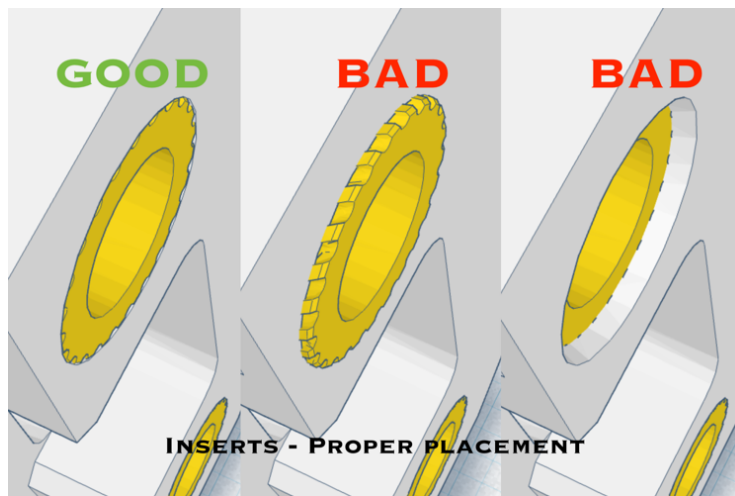
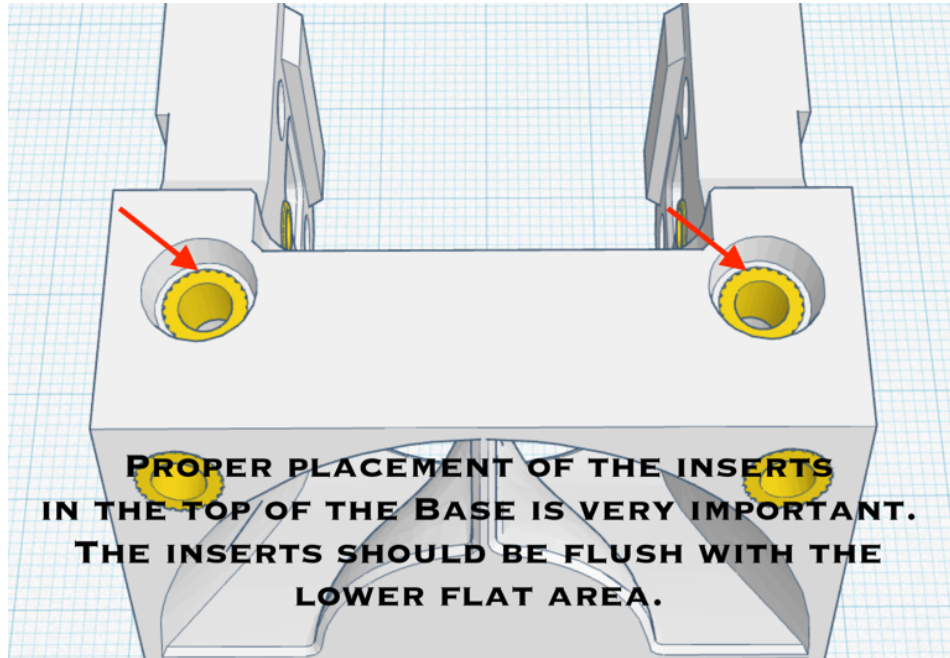



These images show where the threaded inserts are placed in the Hero Me Gen7 Base:

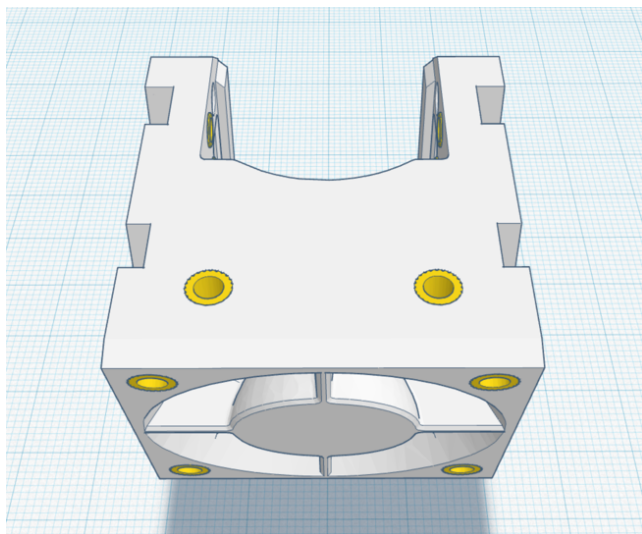
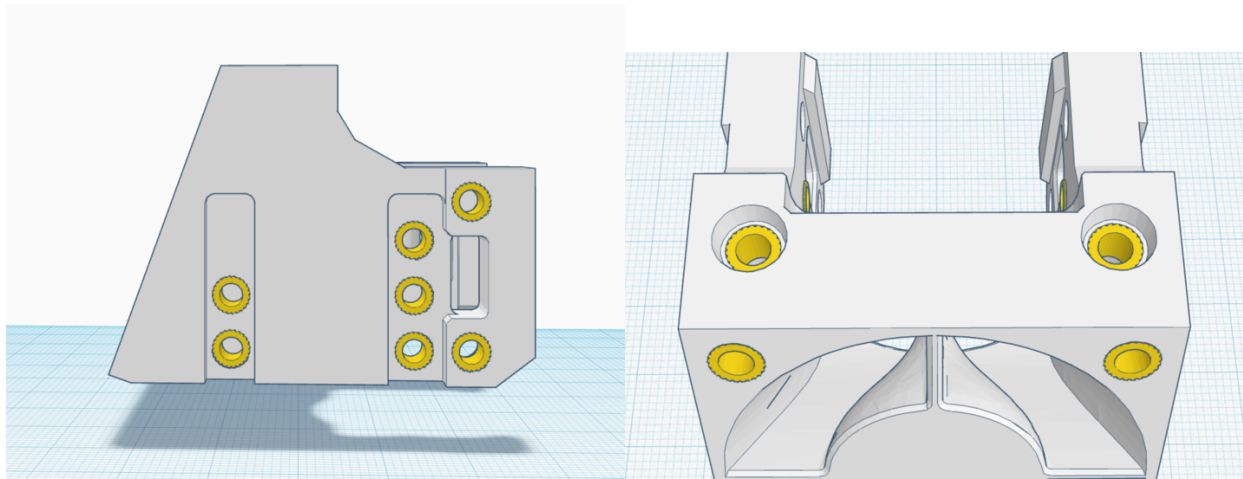
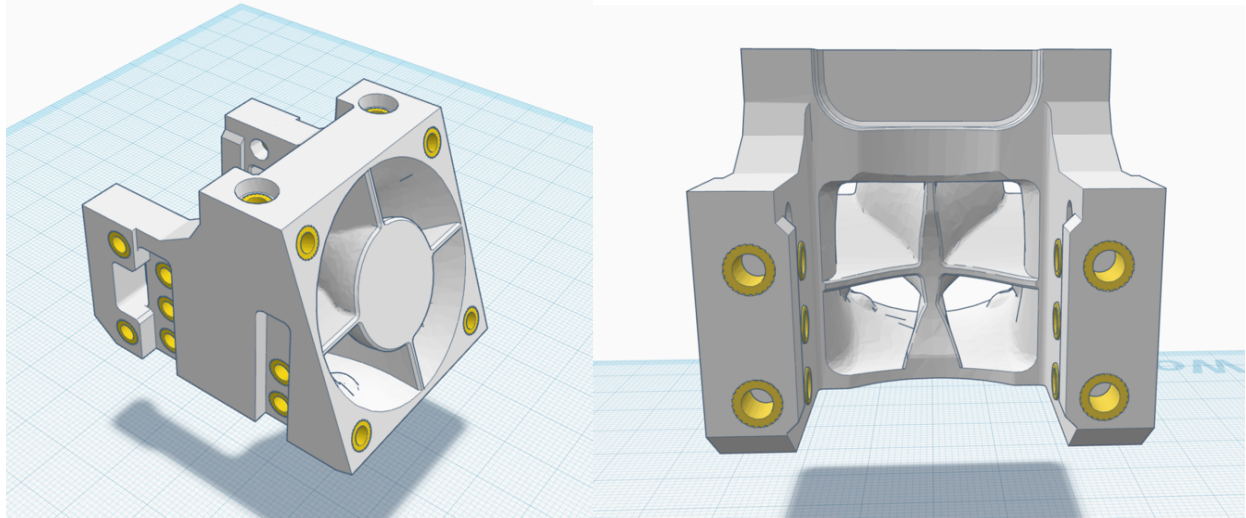

## Disassemble current hotend assembly from the X carriage.

Prepare and make any adjustments, wiring changes, fan changes or additions, or any other changes needed on you hotend wire loom before assembling the Hero Me Gen7 cooling system. Some setups may require the X carriage to be partially or fully removed from the X axis gantry.

## Hero Me Gen7 Reassembly

Before assembly, 'dry fit' all the parts to be sure they will seat properly. During this step take any needed measurements for a PTFE tube to be cut and placed in the Hotend assembly stack, from inside the hotend's heat sink, through the hotend mount(s), riser (if needed), direct drive mount, and into the bottom of the extruder (if used).

For MediaMan3D patrons at the All-Access tier (or higher), I have created a half hour video covering the steps to assemble the Hero Me Gen7 setup. <https://www.patreon.com/posts/hero-me-gen7-two-74554580>

Below are the assembly steps with images that help show the assembly of the Hero Me Gen7 system to your X carriage. While your specific parts may be very different, they all follow the same basic pattern.

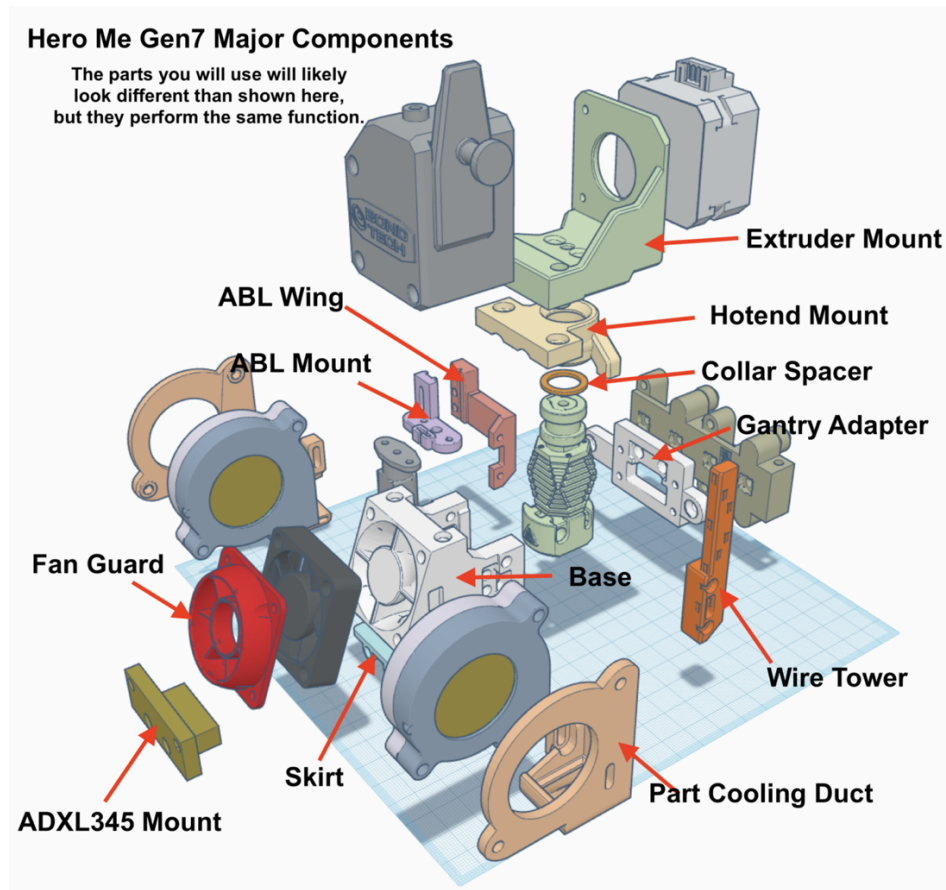

Exploded view with parts named. This example shows a Dragonfly BMO, Bondtech BMG, dual 5015 fans, and a BLTouch mounting to an Exoslide X carriage.

### Hero Me Base and Skirt

Start the assembly of your Hero Me Gen7 printhead platform by attaching the Skirt to the bottom of the Base with 2 M3 screws.

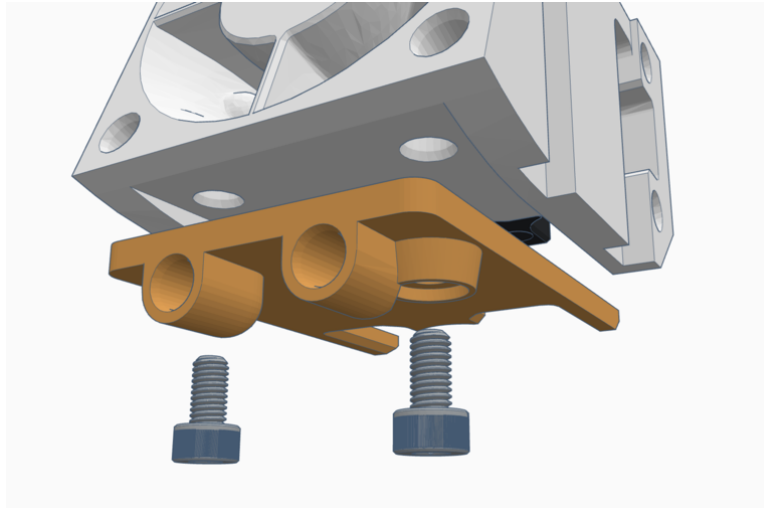

### ABL Sensor

Next: If used, attach the ABL bracket and sensor mounts and ABL sensor.

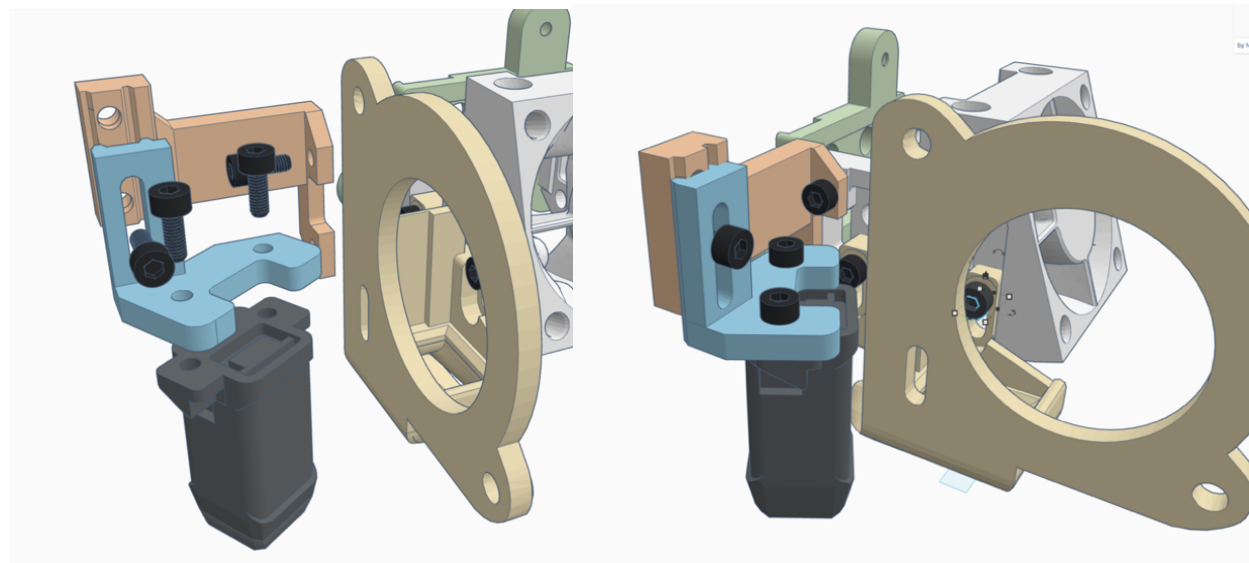

Adjust the height of the ABL sensor to match height defined by the ABL sensor's manufacturer.

Ignore the fact that the part cooling ducts are shown already attached in the photos above. The part cooling ducts are added after the ABL sensor.

## Part Cooling Ducts

Now attach the part cooling duct(s) to the base. Do not add the fans to the ducts yet, they will be added later.

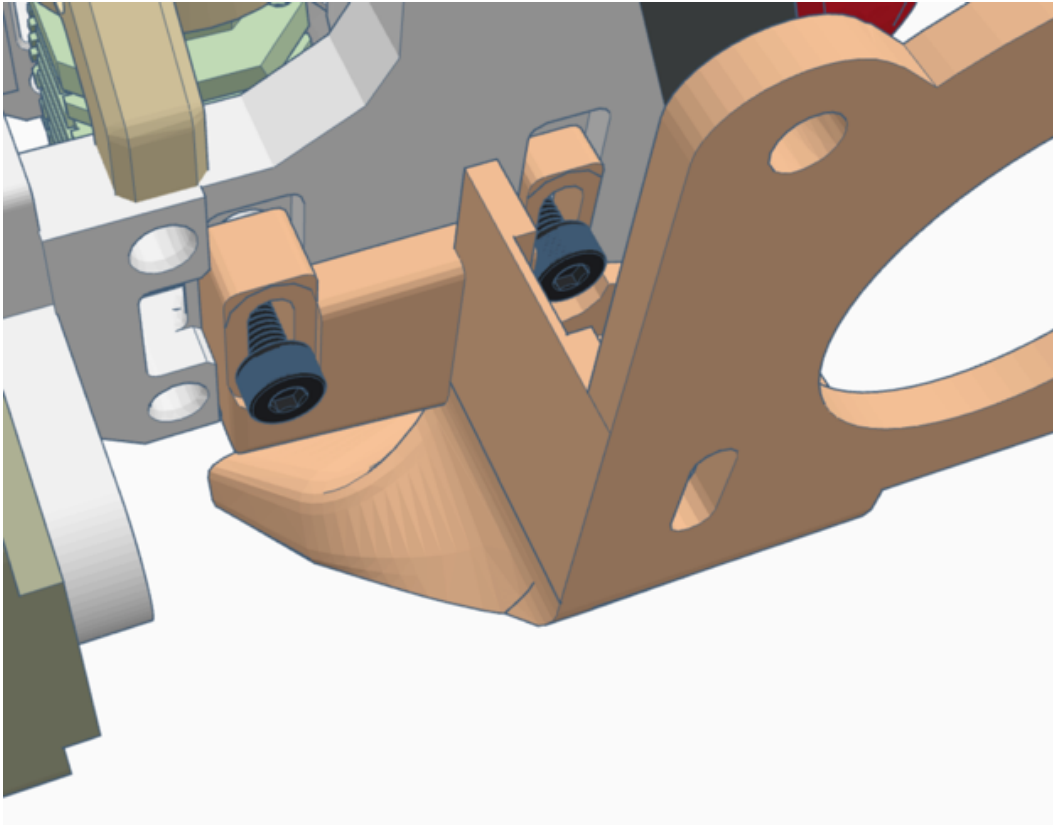

## Hotend Mounts

In a few instances, the hot-end and its mount will need to be assembled after the Hero Me Base and Gantry Adapter have been attached to the X carriage. This is due to some X carriages only having a needed mount point that is within the width of the Hero Me body.

Be sure to check your setup to see if a gantry mount point is behind where the hotend will be placed, if so, they this will have to be done before the hotend is inserted into the Base and mounted to its mount plate. Note that for collar/groove mount based hotends, there is a new retaining system. The E3DV6/Clone mount use two threaded inserts in the back of the collar.



### Collar Mount Example

The hotend is prevented from moving by the M3 screw threads that 'dig in' to the sides of the collar, preventing it from dropping or spinning in place. Because there are different heights of the collar rings on hotends that are V6 style, I provide four different spacers (1mm to 2.5mm in thickness). The E3DV6 and true clones will use one 1mm spacer placed in the collar before inserting the hotend. You will want to test fit your hotend with screws to find the spacer that is correct for your hotend such that the screws are contacting the underside of the top ring on the collar.

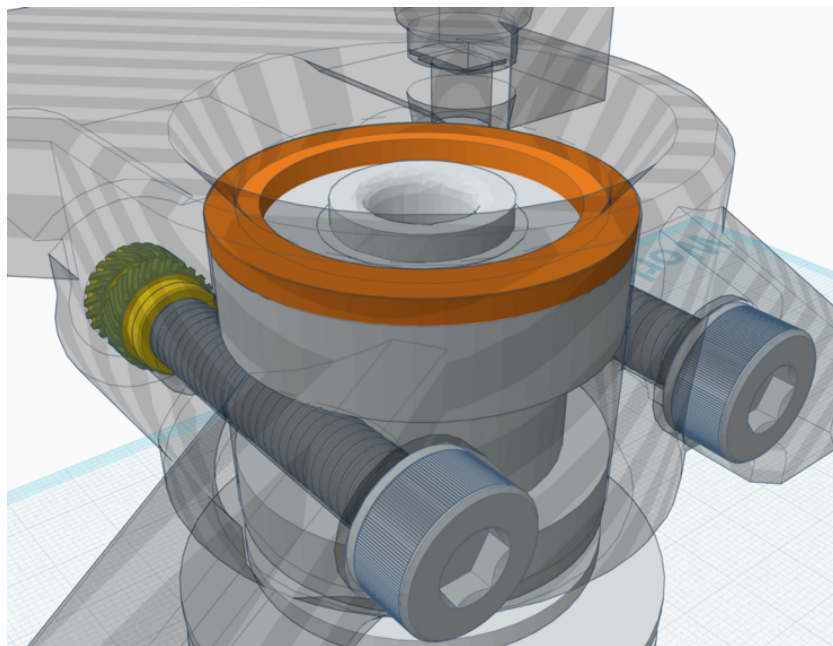
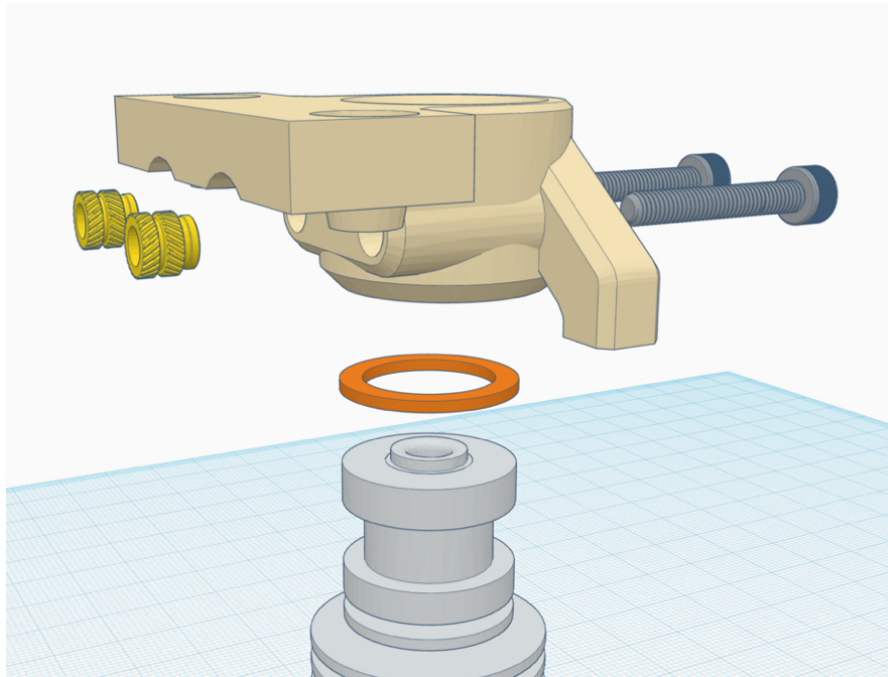

Assemble the hotend into its mount. Mount the hotend assembly to the Base.

**Creality Style Horizontal 2 Screw mount**

It is very important to note that hotends that previously connected directly to the X carriage stand-offs with two M3 screws, no longer do. They are secured to the Hotend mount only. Screws do not continue to the X carriage.

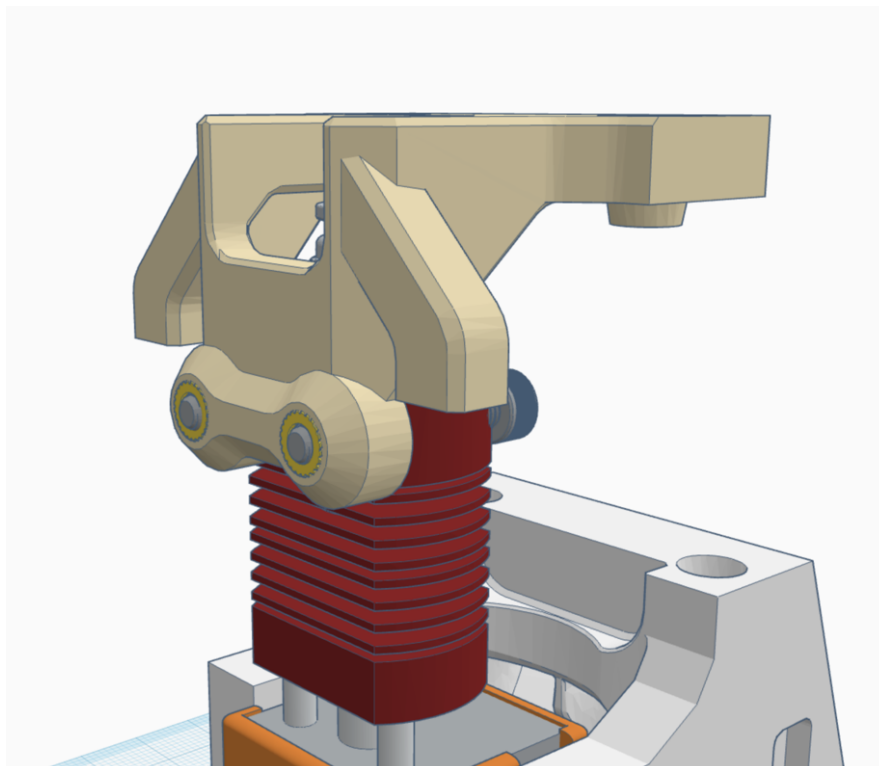
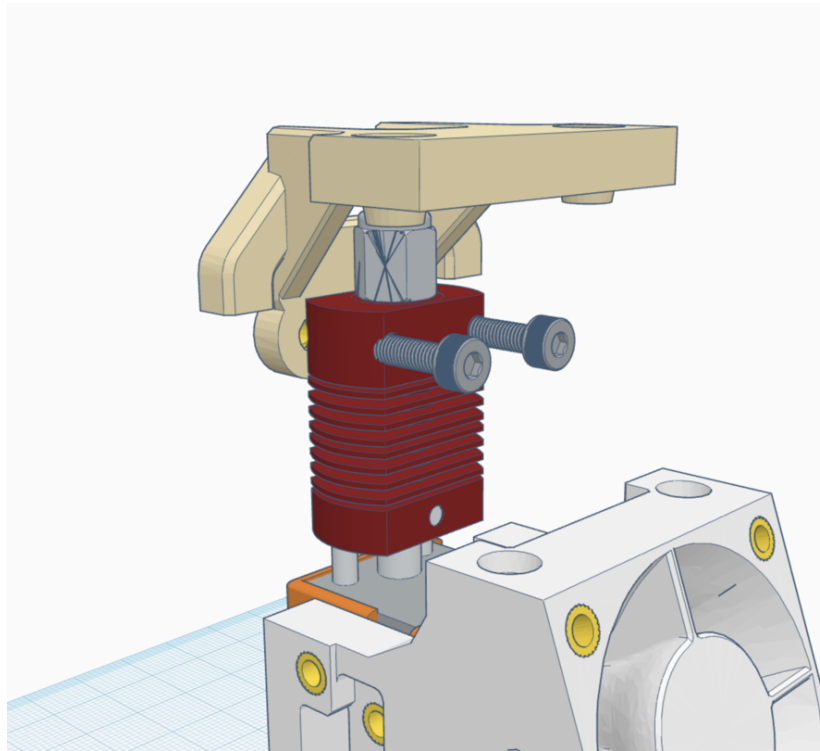



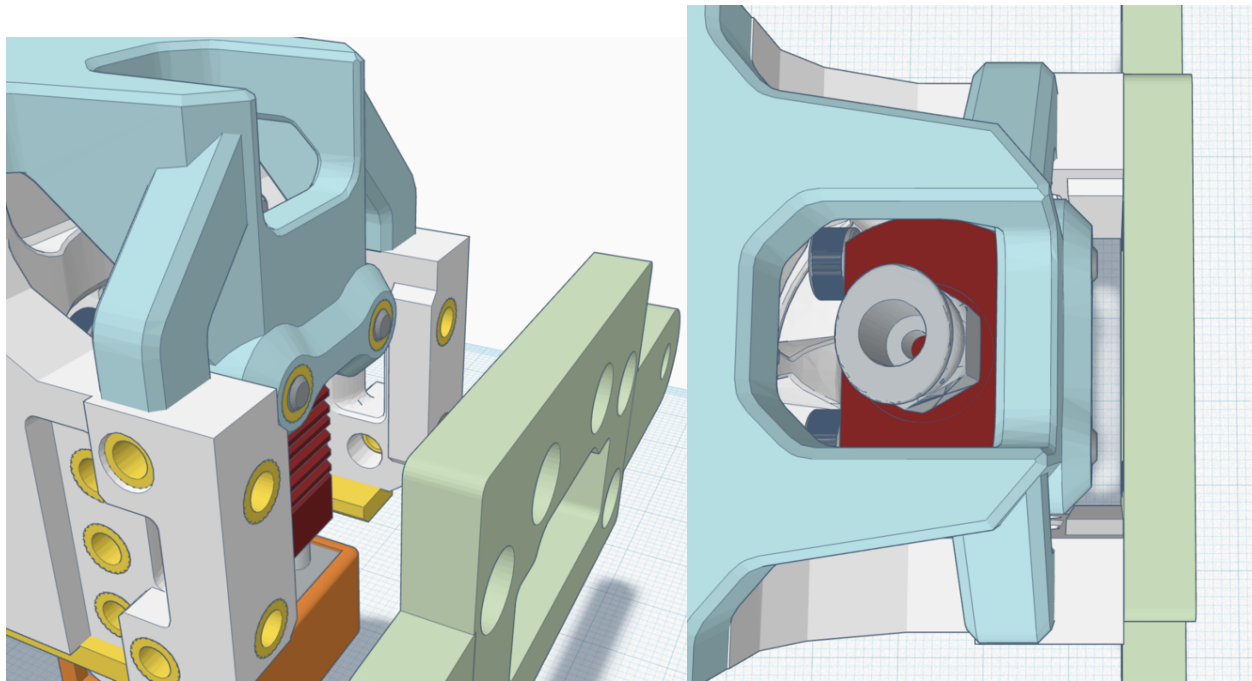

**Bowden Setup**

If direct drive, skip this step. If your setup will be Bowden based, now add two M3 screws into the top of the hotend mount to secure it to the Base.

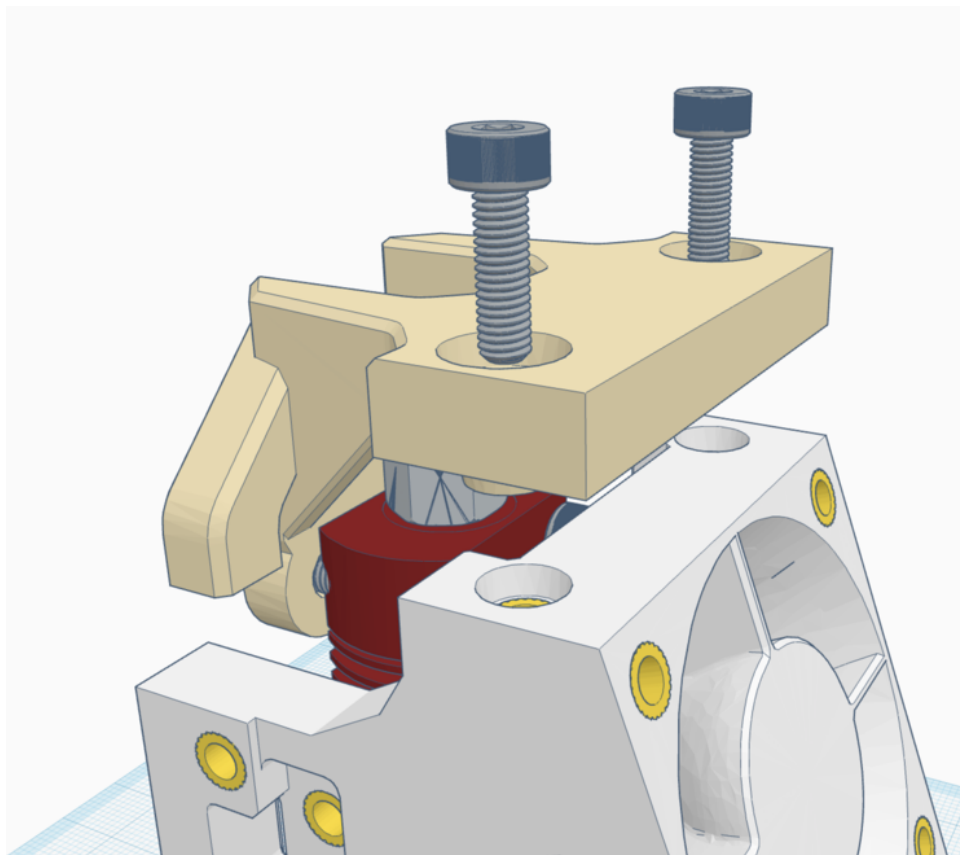

**Cable Management Tower**

As there is no 'chimney' in the Gen7 Base (this was in Gen6 and earlier generations), you will want to route the wires out the back left or right side of the base (behind where the fans mount). Wire management tower STLs are connected to either the new left or the right rear mount points. Note that an ABL bracket can be mounted on either the left or right side of the base using these same mount points. The tower and ABL mount can be 'stacked' on one side if needed.

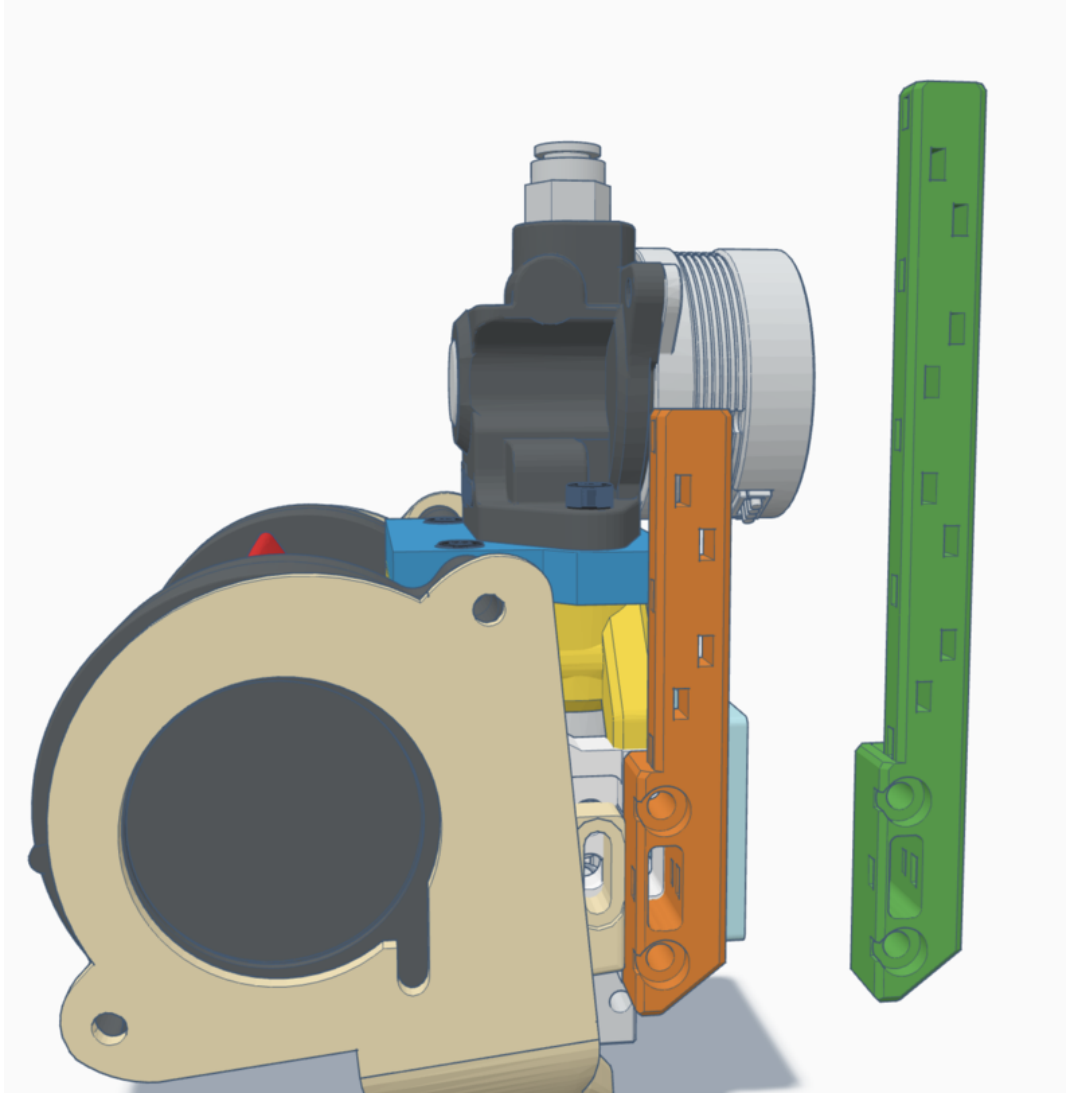

## Extruder Mounts

In addition to the 'Front' and 'Rear' versions of most extruder mounts. There are also optional 'riser' STLs (4mm, 6mm, 10mm) that may be used with some setups with rear facing stepper motors, if you need if needed to raise the height of the stepper to clear over the top of the X carriage.

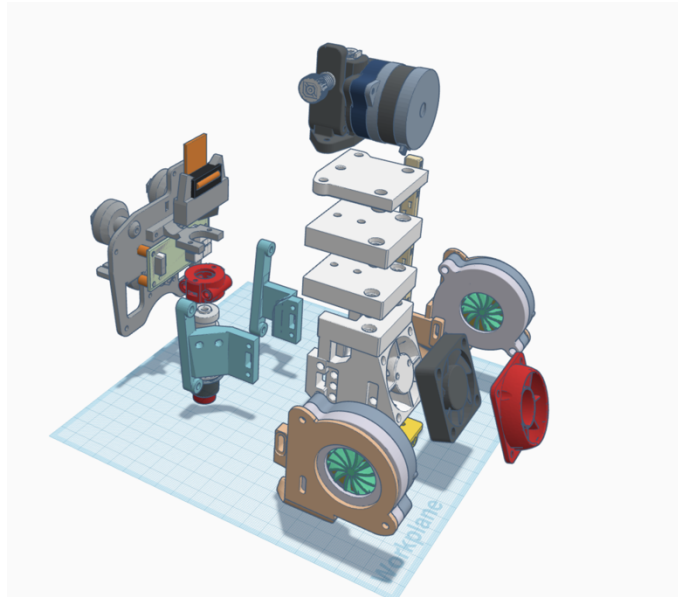

If needed place any riser(s) between the hotend mount and the extruder mount so that a rear facing stepper will clear above the top of a tall X carriage.

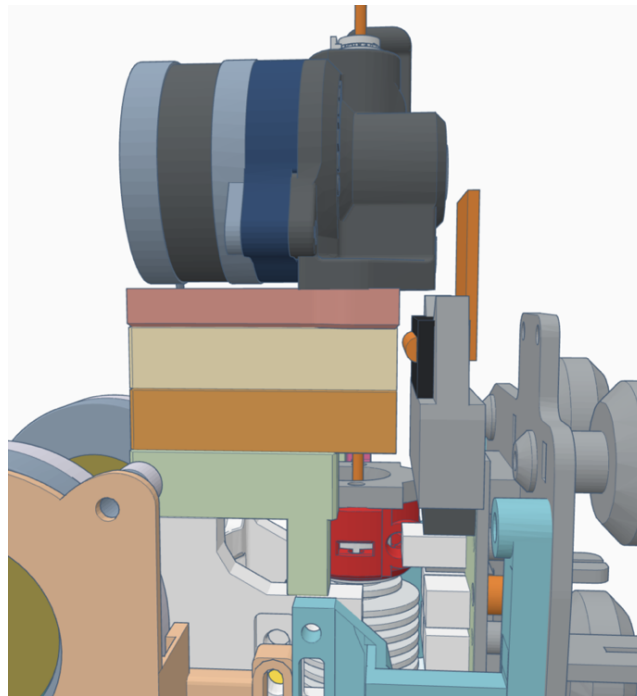

Some extruders must be secured to their mount plate before attaching to the base assembly as their mount points are from under the bottom of the mount plate. Other extruders can be mounted later, as they connect from the top or sides of the mount plate. If the extruder mounts from underneath, once secured you will want to install the PTFE tube into the base assembly and then into the extruder base when securing it.

Attach the extruder mount to the top of the base and hotend mount assembly. Add two M3 screws into the top of the hotend/ extruder assembly. long enough to secure the extruder mount, risers, hotend and base together.

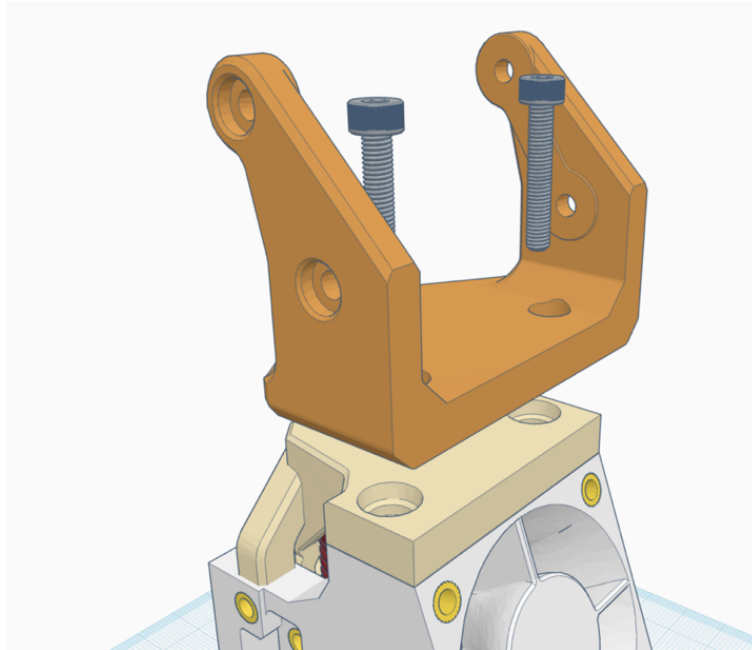

### Gantry Adapter

Attach the Gantry Adapter to the Base.

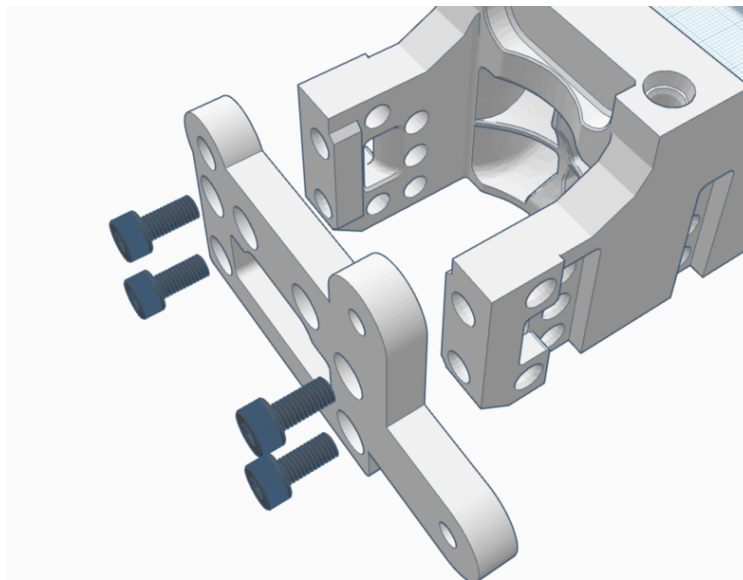

Mount the Hero Me assembly to your X carriage. Depending on your printer model, you may have to loosen or remove the X carriage from the X axis gantry to properly mount the Hero Me assembly to the X carriage.

Once the Hero Me assembly is attached to the X carriage, if needed reassemble the X carriage to the X axis gantry and adjust the printer's offset nut (V-Wheel setups) so that the whole assembly rides smoothly on the rail with no play/slop.

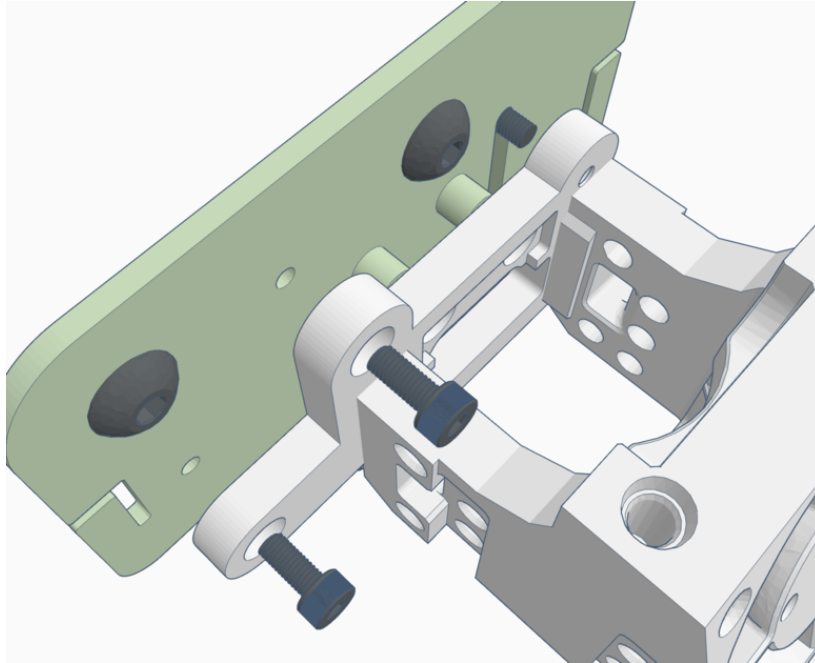

### Special Case Gantry Adapters

Some 3D Printers' X carriages do not have enough mount points to securely hold the Hero Me assembly. For these situations, there are two ways this is resolved,

**Scenario #1:** An M3 screw is inserted through a slot from behind the X carriage and into a threaded insert mount on the Gantry Adapter. Here are a couple examples of these situations:

M3 screws from behind:

#### Ender 5 Pro and Ender 5 Plus

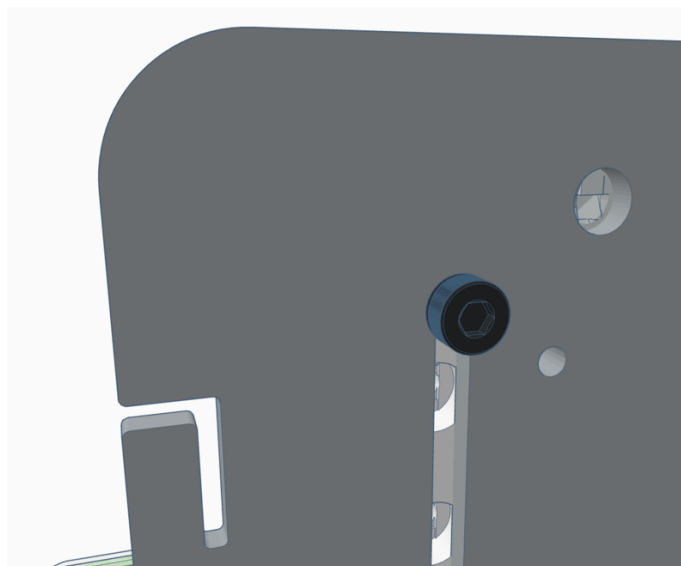

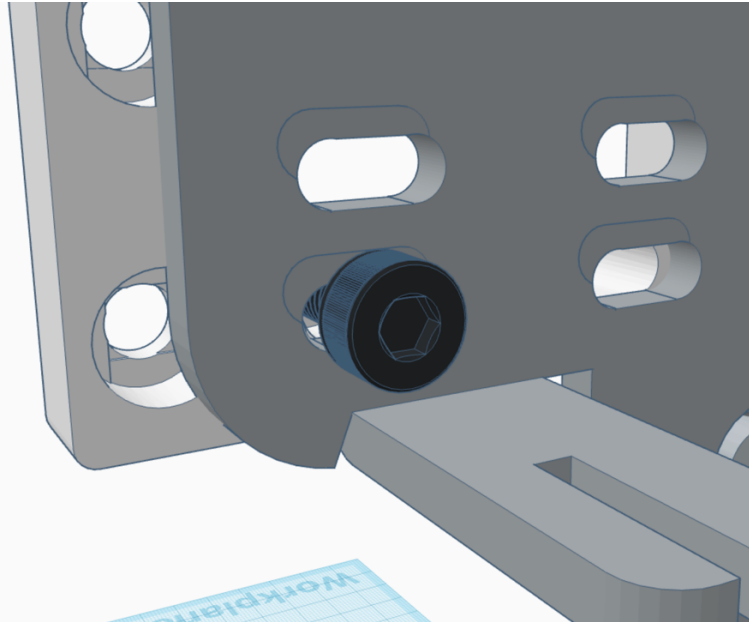

**CR-10S Pro**

These are not the only two printers that have this situation, just examples.

**Scenario #2:** When there are no slots to use, Gantry Clips have been created to help hold the Gantry Adapter to the X carriage. These Gantry Clips are positioned from behind the X carriage plate on one or more edges that lines up with a ‘floating’ mount point on the Gantry Adapter. An M3 screw is used to securely sandwich the X carriage between the Gantry Adapter and the Gantry Clip.

Here are a couple examples of these situations with a Gantry Clip from one or two edges:

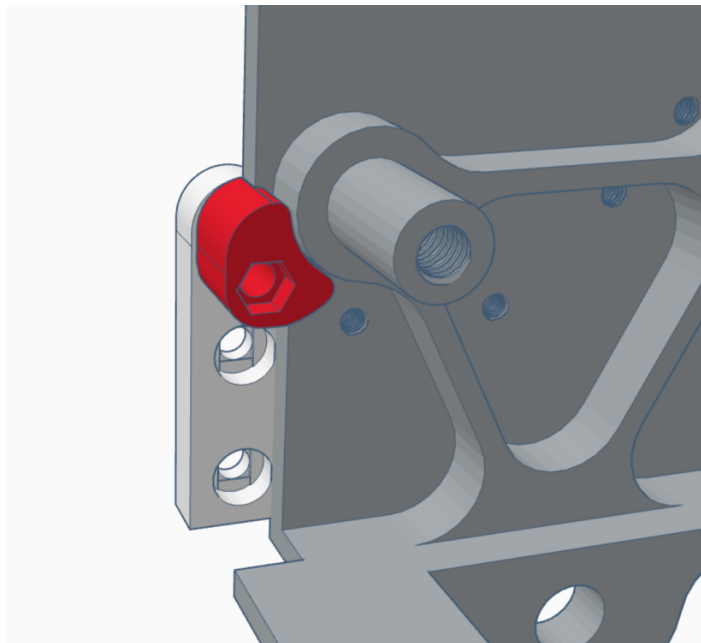
**Micro Swiss Direct Drive Kit (all four versions)**

**Ender 3 V2**

**Ender 3 V2 Neo**

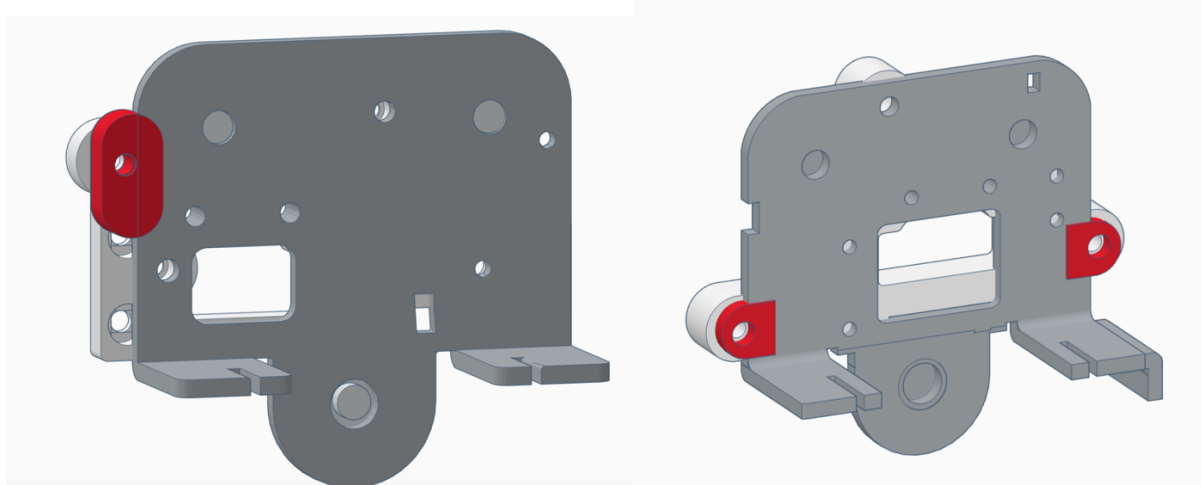

These are just examples, there are other the 3D printer model X carriage mounting that are solved in this way.

**Heat Sink Fan Guard**

Attach the heat sink fan and shroud (if any) to the front of the Base.

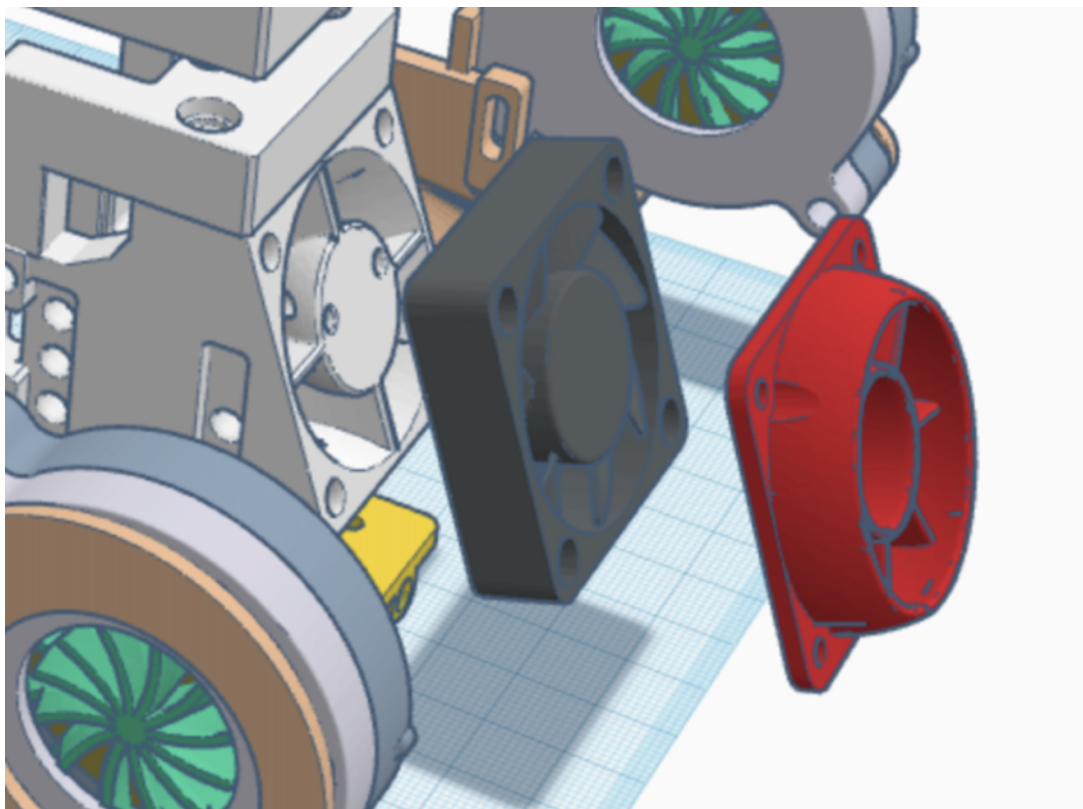

### ADXL345 Mount

Optionally attach an ADXL345 mount and PCB if used and mount that to the front of the Skirt. Optionally add an LED bar between part cooling ducts (only valid for dual fan setups).

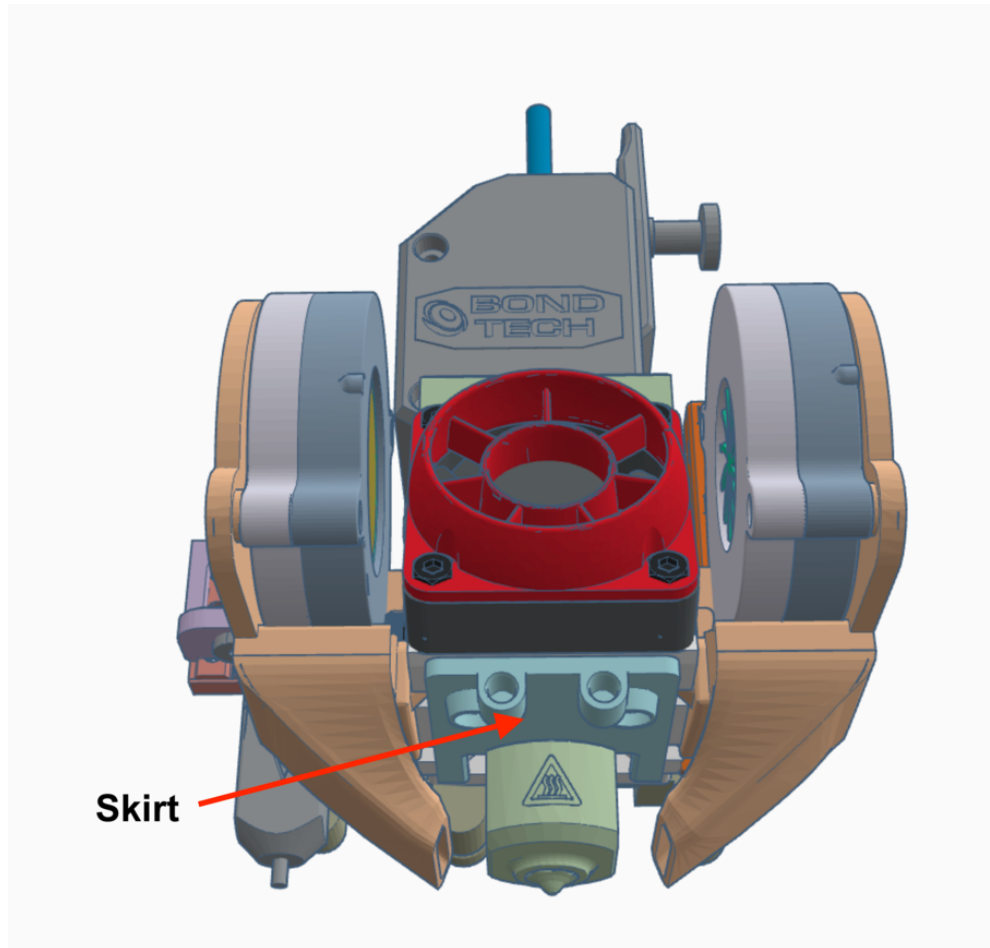

### Proper Height Setting of Part Cooling Fans

The correct vertical positioning of the Part Cooling Ducts is 1.4mm to 1.8mm above the print bed when the hotend nozzle is touching the bed. There is an STL in the Options folder you can print that will make this very easy. It is placed on the bed below the nozzle. The hotend is lowered it have the nozzle sit in the hole in this tool, the sides are set to 1.6mm.

If you attached the part cooling fan(s), you would need to temporarily remove them to do this height adjustment. Loosed the front and rear screw(s), of the part cooling fan(s), but do not remove them.

Adjust the height of the part cooling ducts to be 1.6mm above the build surface when the nozzle is touching the build plate then tighten the two mount screws. Retest the height as it may have moved while tightening the screws. Repeat these steps for the other side.

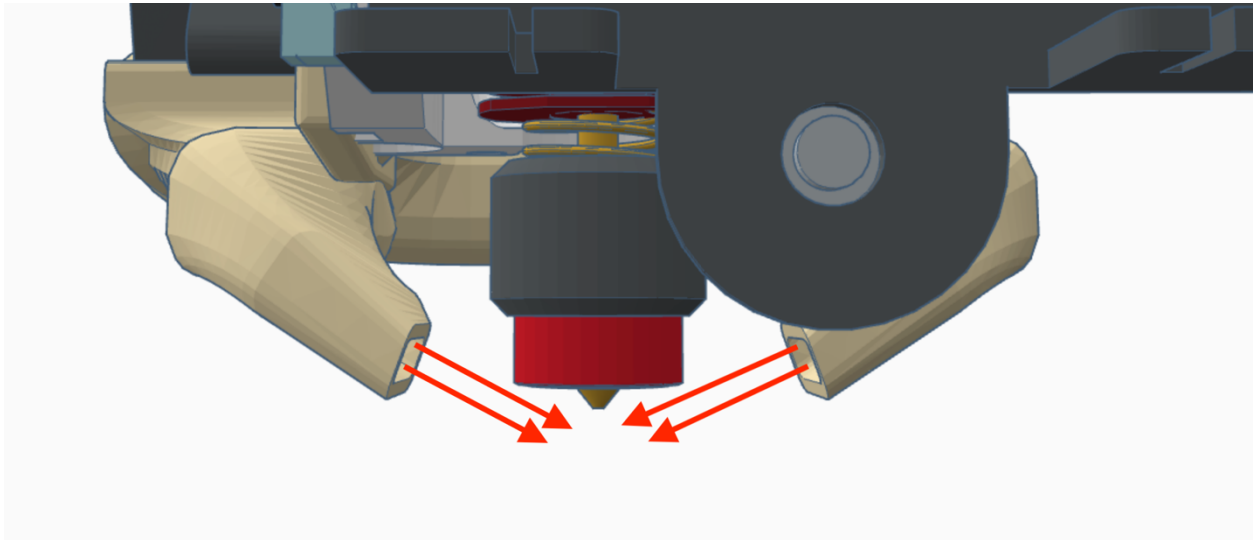

Once this is complete, you can mount the fan(s) to the part cooling duct(s).

The following image shows the correct placement of the Part Cooling Duct tips in relation to the nozzle. Note that the nozzle is NOT centered vertically between the ducts. At first glance it may seem incorrect, but this positioning is correct.

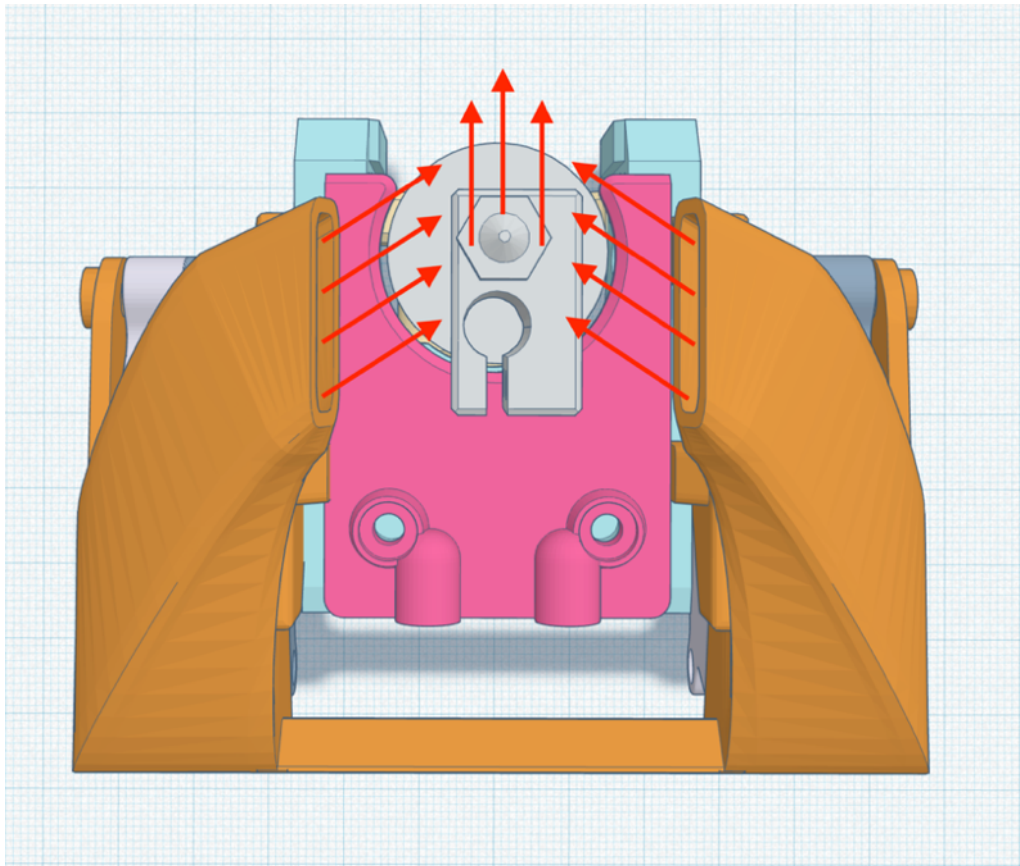

The ducts are channeled to direct the airflow at an angle (upside down Y shaped) to maintain a laminar air flow at the part below the nozzle to greatly reduce turbulence.

Perform cable management and any final wiring. Recheck that all screws are tight.

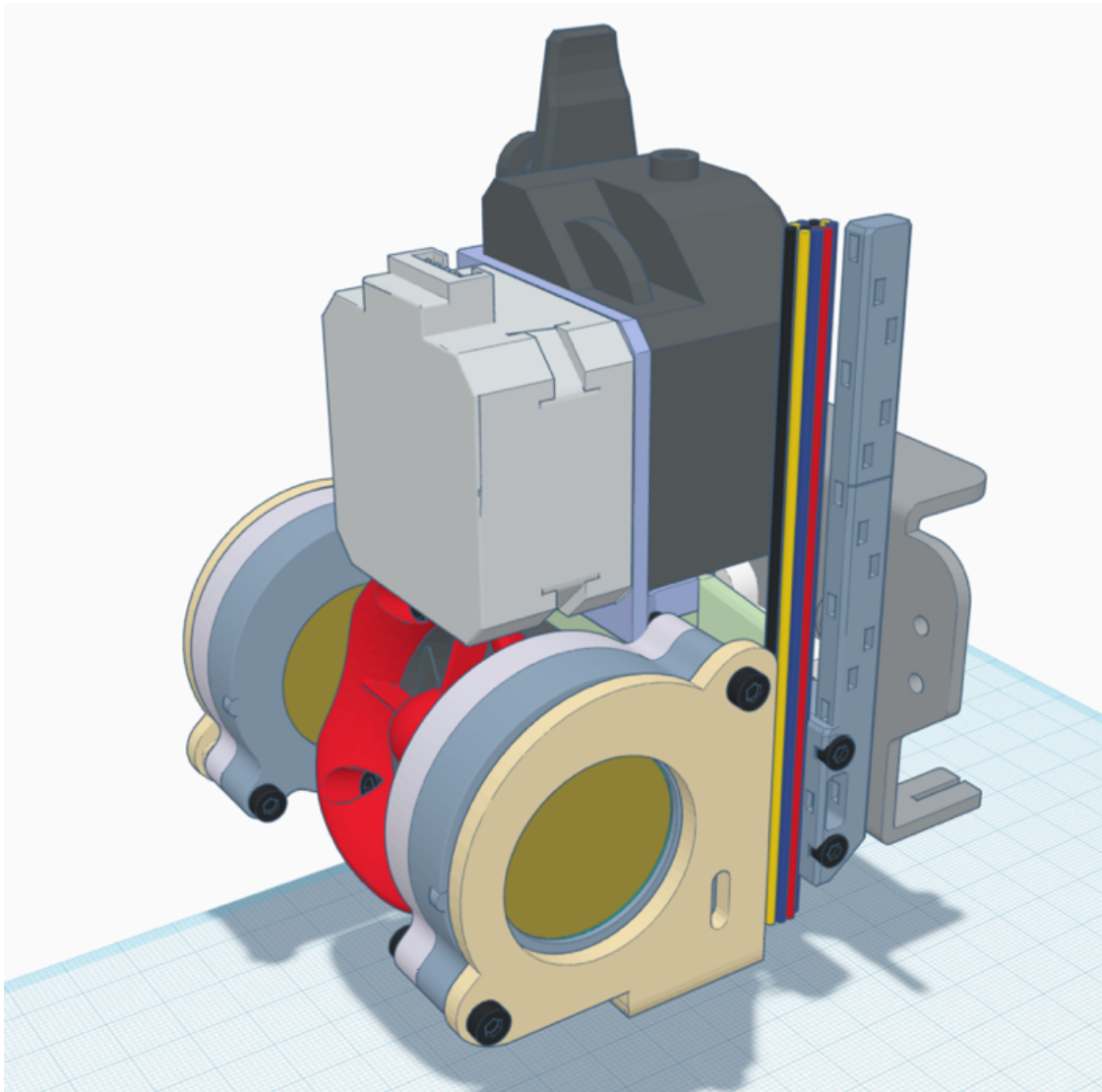

Perform any necessary X axis belt adjustments and any tests that the 3D printer manufacturer recommends after this type of upgrade.

**IMPORTANT:** With the Hero Me Gen7 platform, your nozzle will be moved 9mm further forward than your stock setup. Many 3D printers have Y axis positioning adjustments to compensate for this. If not, you will want to set a new XY offset in your firmware. This is covered in the next section.



## ABL Sensor and Nozzle offsets for Firmware or GCODE

Check that everything is secure and where it belongs. And before you print... You will need to set your printer's Home offset (not to be confused with the ABL sensor offset). The Gantry Adapters for the Hero Me move the hotend's nozzle forward -9mm from the original position.

This move was necessary to allow the Hero Me Gen7 to be compatible with the most printers, hotends, ABL sensors, and fans. The nozzles of all the supported hotends are in the same position in the Hero Me Gen7, allowing the parts cooling ducts to all be accurately designed to cool the part directly below the nozzle tip. The cooling ducts have been CFD calibrated and real-world tested to perform to the optimum.

**Optional:** If you have an ABL sensor, adjust the height of the sensor to the specs provided by the manufacturer. Based upon your printed parts and how the Hero Me is assembled, your setup may vary slightly. To get the best results for your printer, measure your setup's X, Y offsets from the tip of your nozzle to the tip (or center) of your ABL sensor (rounded to the nearest integer). If the ABL is mounted on the left, the X distance in mm will be a negative value for the firmware offset. If mounted on the right side of the hotend, the X distance offset will be a positive number. The Y axis may have a positive or negative number.

To help with measuring the X/Y offset of your ABL sensor, I have created a tool to make it easier to measure. It is called: HMG7.3 ABL Offset Measure.stl and can be found in the Options folder.

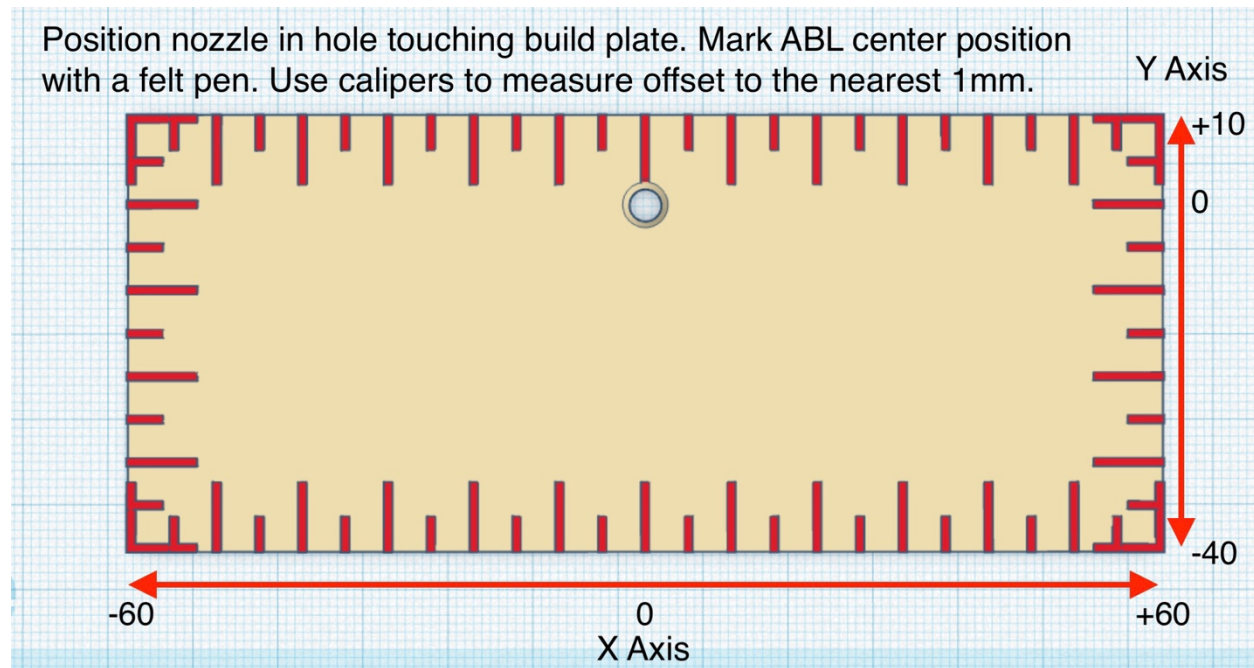

Print this tool plate and use it to measure the X/Y offsets. Each major mark is 10mm and each minor mark is 5mm. Make sure the tool is parallel to the X axis. If your sensor 'tip' is large like an EZABL or a PINDA probe, then mark the center of the probe on the tool in both the X and Y axis direction. Then when you remove the tool, find the point where the two marks cross. You want to be measuring the center of the ABL sensor.

## Setting the Offsets on your Printer

The Marlin setting for the ABL offset can be made in firmware, but it also can be done via GCode.

The firmware setting can be edited/added to the configuration.h file. You would add the following line and replace the X and Y values with the ones you measured for your ABL sensor.

```
#define X_PROBE_OFFSET_FROM_EXTRUDER -50; -distance of probe in whole mm left of the nozzle example only
#define Y_PROBE_OFFSET_FROM_EXTRUDER -10; -front of nozzle, example only
```

Or you can set the ABL sensor offsets in GCode via your slicer software. Add the following line and replace the X and Y values with the ones you measured to the Start GCode in your slicer's settings:

```
M851 X-50 Y-10 ; ABL Sensor offsets - example only
```

The detailed instructions for Marlin firmware and GCode on setting the ABL offset are here:

<https://marlinfw.org/docs/gcode/M851.html>

The Home setting can be made in firmware, but it also can be done via GCode. For Marlin, the Home offset setting can be edited/added to the configuration.h file. Based upon the Gantry Adapter you are using, you would add one of these two lines in the configuration.h file, then recompile and upload to your printer.

```
#define MANUAL_Y_HOME_POS -9
Or
M206 X -46, Y +2 X -37, Y -2; example only
```

Or, you can set the Home offset setting via your slicer software. Based upon the Gantry Adapter you are using, you would add this line to the Start GCode in your slicer's settings:

```
M206 Y-9; Y axis offset
```

In case these values do not place the hotend's nozzle just inside the edge of the build plate when homing the Y axis, you can adjust the Y offset value up or down to work for your setup.

The Marlin firmware detailed instructions on setting the printer's Home offset is here:

<https://marlinfw.org/docs/gcode/M206.html>

To set the edge boundaries when performing a mesh bed level use G29 to set the area to be probed. Here is an example for a bed that is 235mm by 235m:

```
G29 B205 F20 L20 R205
```

Where:

'B' is the back limit of the probing grid.

'F' is the front limit of the probing grid

'L' is the left limit of the probing grid

'R' is the right limit of the probing grid

The detailed instructions for the use of G29 is here:

<https://marlinfw.org/docs/gcode/G029-abl-bilinear.html>

Once you have set the Home offset, perform your printer's bed leveling process.

## 3D Printer Model Specific Notes

### Ender 5 Pro/Plus

When using 5015 fans on the Ender 5 Pro/Plus you will need to reposition the front crossbar down by 40mm to ensure access to the full Y axis build space (and to not crash into the crossbar when homing the printer). Dropping the crossbar has another benefit, full easy view of the first layer of prints that were blocked by the Ender 5 Pro/Plus top frame. Moving the crossbar down by 40mm will have no negative affect on frame strength. There are several mods for this both commercial and free to print. You can search for 'Ender 5 Crossbar' or 'crossbar relocation' in Thingiverse.com and come up with at least a half dozen options.

Here are links to a few STL sets:

<https://www.thingiverse.com/thing:4410969>

<https://www.thingiverse.com/thing:4485125>

<https://www.thingiverse.com/thing:4912123>

<https://www.printables.com/model/100469-ender-5-front-crossbar-relocator>

<https://www.thingiverse.com/thing:3876601>

There is also an issue with some Ender 5 Plus printers, in that with some hotend setups (not just Hero Me Gen7) the hotend can collide with the stock bed rod holders. Bondtech has created parts to replace the stock bed rod holders that fix this issue. While they sell them, they also offer the STLs for free:

Bed Rod Holder Set for Ender-5 Plus

<https://www.bondtech.se/product/ddx-bed-rod-holder-set-ender-5-plus/>

Bed Rod Holder Set for Ender-5 Plus (Free STLs)

[https://www.bondtech.se/downloads/STL/Crealty/Bed\\_rod\\_holder\\_for\\_Ender-5-Plus.STL](https://www.bondtech.se/downloads/STL/Crealty/Bed_rod_holder_for_Ender-5-Plus.STL)

If you have any Ender 5 series and are using any of the ABL sensor mounts, you may need to use a spacer to clear the metal clip that holds the belt on the left side. This applies to both the OEM gantry plate and the PrinterMods.com MDD plate. The spacer file is: Ender\_5\_ABL\_Spacer.stl and is found in the ABL Mounts/Other ABL Sensors/ folder. The firmware offset for the Y axis will increase by -6 (spacer width).

## Hero Me Gen7 Orientation and Assembly Videos

If you are a MediaMan3D patron at the All-Access tier (or higher) you have access to the Hero Me Gen7 STL parts orientation and assembly videos via these Patreon posts:

<https://www.patreon.com/posts/hero-me-gen7-stl-74555664>

<https://www.patreon.com/posts/hero-me-gen7-two-74554580>

Please let me know if you find issues with this assembly process or have a better way to do it. These are the basic steps, and there will be some esoteric assemblies that may need a very different process due to the unique nature of the setup (e.g., Anycubic Vyper setup).

Please provide feedback on anything Hero Me Gen7 related via the #hero-me-gen7 or #hmg7-support channels in the Hero Me Discord server. Be sure to review the #gen7-faqs channel first before posting your question as it may already be answered.

## Thanks and Credits

I would especially like to thank James Tongue (Hangtight) and Craig West (ACWest) for their contributions to the development of the Hero Me Gen7 Platform.

James has rebuilt much of the Hero Me Gen7 components into STEP format. James and I collaborated on the modular functionality of Gen7. Craig did the development of the part cooling ducts' laminar airflows. The cooling ducts have been CFM tested and validated to have the optimum focused airflow across the part below the tip of the nozzle.

Thank you for choosing the Hero Me Gen7 to be part of your 3D printing experience! Please post a make or remix on the Hero Me Gen7 Printables.com project page and/or post a make to one of the many 3D printer Facebook groups. Tell your 3D printing friends about the Hero Me Gen7!

Printables.com: <https://www.printables.com/model/39322>

Thank you,

Andy  
MediaMan3D

**Hero Me Swag:** <https://hero-me-shop.creator-spring.com>

**Website:** <https://merlinmedia.com>

**FaceBook:** <https://www.facebook.com/MediaMan3D>

**Twitter:** <https://twitter.com/mediaman3D>

**YouTube:** <https://www.youtube.com/@MediaMan3D>

**Print Shop:** [https://www.cubee3d.com/store/Merlin\\_Media](https://www.cubee3d.com/store/Merlin_Media)

**Affiliates: Wham Bam**

**Systems:** <https://whambam3d.com?aff=48>

10% Discount Code (valid in 2023): MediaMan2022

**3D Design Libraries:**

<https://www.printables.com/social/56045-mediaman3d/>

<https://www.thingiverse.com/mediaman>

<https://thangs.com/mediaman3d>

<https://cults3d.com/en/users/MediaMan3D/creations>

<https://www.myminifactory.com/users/MediaMan3D>

**Patronage:**

<https://www.patreon.com/MediaMan3D>

<https://www.buymeacoffee.com/MediaMan3D>

<https://paypal.me/arsoderberg>

## Change Log

- The Change Log is now in its own separate document called: \_Hero Me Gen7.3.2 Change Log V1.4.pdf